

RECONSIDERED
DRAINAGE REPORT
FOR THE

REPAIR AND IMPROVEMENT OF THE
ANTAYA DRAIN

TOWN OF TECUMSEH
COUNTY OF ESSEX



FINAL (COUNCIL CONSIDERATION)
16 MARCH 2022
MARK D. HERNANDEZ, P.ENG.
FILE NO. 17-6818
TECUMSEH FILE NO. E09AN(1)



Mayor and Council
Town of Tecumseh
917 Lesperance Road
Tecumseh, Ontario
N8N 1W9

Drainage Report for the
Repair and Improvement of the
ANTAYA DRAIN
Town of Tecumseh
County of Essex

Mayor and Council:

Instructions

In accordance with Section 78 of the Drainage Act, Council appointed Dillon Consulting Limited on 14th November, 2017 to prepare a report for the repair and improvement of the Antaya Drain.

Summary of Changes to Original Report

Our original report dated 16 March 2022 was provisionally adopted by Town of Tecumseh council on February 8th, 2022. Revisions to the assessment schedules were discussed at the subsequent Court of Revisions meeting held on March 8th, 2022, and the report was referred back to the Engineer at that time. The changes to the schedule of assessments are summarized as follows:

- The frontage component of the benefit assessment for Roll No. 570-48900 has been revised to result in a fairer assessment when compared to similar properties. This change is reflected in Schedule 'C' for assessment of construction costs, and in Schedule 'E' for assessment of future maintenance costs.

3200 Deziel Drive
Suite 608
Windsor, Ontario
Canada
N8W 5K8
Telephone
519.948.5000
Fax
519.948.5054

- The special benefit assessment to property Roll No. 570-48950 for the supply and installation of stone erosion protection was previously under Schedule 'D' for 'Non-Agricultural Lands'. This special benefit item has been relocated under Schedule 'D' to 'Agricultural Lands'.
- The factored areas were revised for property numbers 1-10 to be consistent between Schedule 'C' and Schedule 'E'.

Watershed Description

The Antaya Drain is an open drain that commences on the boundary of Lot 152 and Lot 153 of Concession 3, approximately 90 metres south of the southerly limit of Wildberry Crescent. The drain flows northerly, parallel with Lesperance Road, and then turns east continuing to its outlet at the East Townline Drain at Manning Road (County Road No. 19).

The Antaya Drain watershed consists of 15.67 hectares (38.78 acres) and comprises of land under intense agricultural production with cash crops, and some residential land use. There is little topographic relief. The soils are predominantly Brookston clay, according to the Ontario Soil Survey which are poorly drained soils. Some of the agricultural land parcels are systematically tiled.

Drain History

The recent history of Engineers' reports for the Antaya Drain follows:

- 12 November 1971 by C. G. R. Armstrong, P.Eng.: The recommended work included the construction of the Antaya Drain and one farm access bridge.

On-Site Meeting

We conducted an on-site meeting on 8th February, 2018. A record of the meeting is provided in Schedule 'A', which is appended hereto.

Public Information Centre

A Public Information Centre (PIC) was held virtually by the Town on 26 October, 2021 to present to the landowners the report and recommended works for the repair and improvement of the drain, and to

provide an opportunity for questions and/or comments. As a result of the meeting, the area assessed of two properties were modified to reflect the current drainage patterns, which differed from the 1971 Antaya Drain report.

Survey

Our survey and examination of the Antaya Drain was carried out in August, 2018. The survey comprised the recording of topographic data and examining the channel for available depth necessary to provide sufficient drainage. We commenced the survey at the outlet of the drain to the East Townline Drain. We then proceeded upstream along the channel, parallel to and south of the Canadian Pacific Railway, turning south between lot lines 152 and 153. The survey continued to its head near the line between Lots 152 and 153, Concession 3, south of Wildberry Crescent.

Soil sampling was conducted in May 2021 along the Antaya Drain within the residential properties in compliance with Provincial Excess Soils regulations. Soil analysis results indicate that the soils within the residential area of the Antaya watershed are suitable for re-use on residential lands.

Design Considerations

Since the previous 1971 Drainage Report, there have been substantial changes to the upper portions of the drain that were not conducted under the Drainage Act. The drain extent and watershed have been revised as a result.

The drain has been designed to convey a 1 in 2 year design storm which is typical for a watershed that is primarily agricultural. Due to the upstream residential area, the 1 in 5 year design storm was also examined to ensure peak flows remain within the banks of the channel.

Existing Conditions and Recommendations

Our survey revealed a significant amount of overgrown brush and vegetation with frequent accumulations of debris, forming blockages within the lower portion of the drain. The drain will require a bottom



clean out to the design grade specified on the attached profile and brushing of the drain banks.

The upper portion of the drain has experienced substantial changes from the previous report due to residential development. In particular, a portion of the drain north of Wildberry Crescent has been infilled, and a portion of the drain south of Wildberry Crescent has been intercepted by a ditch inlet catchbasin that outlets to the storm sewer under Wildberry Crescent, excluding it from the watershed boundary. We therefore recommend the Antaya Drain be abandoned from Station 1+025 to Station 1+170 in accordance with Section 19 of the Drainage Act.

We recommend the Antaya Drain be reinstated between Station 0+920 and Station 1+025. Reinstating the drain within these station will require the replacement and restoration of an existing yard catch basin that was installed by adjacent land owners to provide drainage as the ditch had been filled in. This yard catch basin is part of the required works, but is not considered part of the Antaya Drain for purposes of future improvements and future maintenance. Excess soils generated in the excavation of the drain are recommended to be spread over the adjacent lands in order to avoid additional costs associated with trucking the material offsite.

Existing residential properties on Strawberry Drive that back on to the Antaya Drain are required to have separate rearyard drainage systems to convey water to the storm sewers along Strawberry Drive, and therefore have not been included in the Antaya Drain watershed. Survey and site inspection revealed that some of these properties no longer have rearyard drainage systems. Some properties have a drainage connection into the Antaya Drain. These connections are to be removed and reconnected to the storm sewer along Strawberry Drive. All future drainage connections from these properties are to be made to the Strawberry Drive storm sewer and not to the Antaya Drain.

Existing drainage structures have been designated numbers for ease of reference between specifications and drawings.



The locations, dimensions, condition and use of each structure are as follows:

Bridge No. 1: Station 0+059 (Roll No. 570-48810 Enbridge Gas Ltd.)

A 9.4 m long, 900 mm diameter corrugated steel pipe (CSP) with no end wall treatment currently exists in the drain. It is evident by the adjacent row of cedar trees and fence that this culvert does not serve as an access to property Roll No. 570-48810. Said property has access over the East Townline Drain from Manning Road.

Bridge No. 1 does not have any reference in previous drainage reports and is assumed to have been installed outside of the Drainage Act, and is substantially below the previous and proposed design grade. We therefore recommend this culvert be removed.

Bridge No. 1A: Station 0+080

Bridge No. 1A is required in order to access the specified working corridor located on the north side of the drain, opposite to the north limit of the Enbridge Gas property between Station 0+000 and Station 0+065.

We recommend a 13.5 m long, 600 mm diameter high density polyethylene (HDPE) pipe complete with sloping stone end walls with filter fabric underlay providing a minimum 7.3 m driveable top width.

Bridge No. 2: Station 0+688 (Roll No. 570-00500 Hydro One Networks Inc.)

A 6.3 m long, 600 mm diameter corrugated steel pipe (CSP) with no end wall treatment and grassed driveway surface exists and was specified the previous 1971 report. It provides access continuity for the Hydro One corridor lands and is not required for farming purposes. Farm accesses are evident from Lesperance Road to the west and County Road No. 19 to the east. It is deficient in top width and has reached the end of its serviceable life. We recommend this culvert be replaced with a new 13.0 m long, 450 mm diameter high density polyethylene (HDPE) pipe complete with sloping stone end walls with filter fabric underlay providing a minimum 7.3 m driveable top width.

Allowances

Throughout the length of the work, the excavated material is to be disposed of as set out in the Special Provisions in Schedule 'F' herein. In accordance with Section 30 of the Drainage Act, we determined the amount to be paid to the owners for damages to lands and crops (if any) occasioned by the operation of equipment and the disposal of material excavated from the drain. The allowance for damages is calculated at a rate of \$3,707 per hectare, (\$1,500 per acre) within the primary working corridor where drain spoils are being disposed of and leveled on agricultural lands or lands used for agricultural purposes.

For the secondary working corridor, where access is required for drain repairs, surface inlet repair or to obtain access to the primary working corridor, an allowance for damages is calculated at a rate of \$1,854 per hectare (\$750 per acre).

In accordance with Section 29 of the Drainage Act, it was determined allowances be given at a third of the rate of \$17,300 per hectare (\$7,000 per acre) for land taken for the purpose of new working corridor for access to the drain, drain improvements and future maintenance. Allowances were provided to residential properties abutting the drain between Station 0+820 and 1+025, and to property Roll No. 590-00500 for a new working corridor on the north side of the drain between Station 0+000 and Station 0+080, and on the west side of the drain between Station 0+630 and Station 1+025. Property Roll No. 590-00500 also received allowances for a new access corridor located along the south west boundary of the property. The total Section 29 allowances for all lands was calculated to be \$4,000.00. Allowances are based on new working corridor as specified in Schedule 'F' herein.

Cost Estimate

Based on our review of the history, the information obtained during the site meeting and our examination and analysis of the survey data, we recommend that the Antaya Drain be repaired and improved as described below:



Item	Description	Amount
	<u>OPEN DRAIN WORK</u>	
1.	Brushing of the drain from Station 0+000 to Station 0+920 including the disposal by burning on-site or removal off-site with trimming and/or removal of existing trees as required to accommodate the drainage works. Work includes trimming of branches overhanging the drain, and cut and removal of mature trees within the limits of drain banks.	\$10,000.00
2.	Excavation and levelling of excavated materials works, as follows:	
	a) Excavation of the drain bottom only from Station 0+000 to Station 0+850, totalling approximately 850 lineal metres of drain and approximately 200 m ³ of material, including spreading and levelling 190 m ³ within the working corridor between Station 0+065 and Station 0+850.	\$8,000.00
	b) Excavation of the drain bottom only from Station 0+850 to Station 0+920, totalling 70 lineal metres of drain and approximately 20 m ³ of material.	\$600.00
	c) Excavation of new drain from Station 0+920 to Station 1+025, totalling approximately 105 lineal metres of drain and approximately 190 m ³ of material.	\$2,500.00
	d) Spreading of excavated material originating from the drain from Station 0+850 and 1+025 to a maximum of 100 mm thickness (approximately 210 m ³) over lands fronting westerly drain bank. Work includes forming of swale graded towards drain at each property line.	\$850.00

Item	Description	Amount
	<p>e) Strip and salvage topsoil of full depth (minimum 100 mm thickness) from footprint of the new drain from Station 0+920 to Station 1+025. Work includes placement and fine grading of salvaged topsoil over the new drain banks at a minimum 50 mm thickness (approximately 25 m²). Topsoil material without deleterious material, subject to approval by the Drainage Superintendent, shall be stockpiled within the designated working corridor and kept as far as possible from the drain top of bank. Stockpiled topsoil shall be contained with sediment erosion control and kept separate from other drain excavation materials for future use.</p>	\$600.00
	<p>f) Strip, salvage, restore, and fine grade topsoil, a minimum 100 mm depth and approximately 20 metres wide off of westerly top of bank from Station 0+850 to Station 1+025. Topsoil material without deleterious material, subject to approval by the Drainage Superintendent, shall be stockpiled within the property limits of which it originated. Stockpiled topsoil shall be contained with sediment erosion control and kept separate from other drain excavation materials for future use.</p>	\$4,800.00
3.	<p>Hydraulic seeding of new drain banks from Station 0+850 to Station 1+025 (approximately 470 m²).</p>	\$2,750.00
4.	<p>Broadcast seeding of area west of top of bank from Station 0+850 to Station 1+025 approximately 20 metres wide (approximately 2,060 m²).</p>	\$5,500.00

Item	Description	Amount
5.	Stone erosion protection (SEP) works, as follows:	
	a) Station 0+415 – Supply and place 15 m ² (300 mm thick) of stone erosion protection (SEP) including new filter fabric underlay on the outlet of the private swale drain to repair bank failure on the south side of the drain.	\$1,500.00
	b) Station 0+868 – Supply and place 4 m ² (300 mm thick) of stone erosion protection (SEP) including new filter fabric underlay on the outlet of new private swale drain outlet on the west side of the drain.	\$400.00
	c) Station 0+890 – Supply and place 7 m ² (300 mm thick) of stone erosion protection (SEP) including new filter fabric underlay on the outlet of the private swale drain to repair bank failure on the west side of the drain.	\$750.00
	d) Station 0+919 – Supply and place 4 m ² (300 mm thick) of stone erosion protection (SEP) including new filter fabric underlay on the outlet of the private swale drain to repair bank failure on the west side of the drain.	\$400.00
	e) Station 0+938 – Supply and place 4 m ² (300 mm thick) of stone erosion protection (SEP) including new filter fabric underlay on the outlet of new private swale drain outlet on the west side of the drain.	\$400.00
	f) Station 0+961 – Supply and place 4 m ² (300 mm thick) of stone erosion protection (SEP) including new filter fabric underlay on the outlet of new private swale drain outlet on the west side of the drain.	\$400.00



Item	Description	Amount
	g) Station 0+983 – Supply and place 4 m ² (300 mm thick) of stone erosion protection (SEP) including new filter fabric underlay on the outlet of new private swale drain outlet on the west side of the drain.	\$400.00
	h) Station 1+006 – Supply and place 4 m ² (300 mm thick) of stone erosion protection (SEP) including new filter fabric underlay on the outlet of new private swale drain outlet on the west side of the drain.	\$400.00
6.	Remove and dispose of existing yard catch basin (YCB) at Station 0+983. Supply and install new 450 mm diameter high density polyethylene (HDPE) YCB 2 m west of current location, complete with cast iron grate and 'Big-O' leader pipe to new drain. Work includes reconnecting existing inlets, re-grading of land toward CB, and fine grading and re-seeding disturbed areas.	\$1,550.00
7.	Temporary Silt Control Measures During Construction	<u>\$800.00</u>
	SUB-TOTAL – EXCLUDING SECTION 26 COSTS	\$42,600.00
8.	Allowance under Section 29 & 30	\$7,700.00
9.	Survey, Soil Sampling & Analysis, Report, and Assessment	\$25,000.00
10.	Expenses and incidentals (cost portion)	\$1,250.00
11.	Tender Documents and Final Inspection	\$1,000.00
12.	ERCA application review and permit fee	<u>\$800.00</u>
	TOTAL – EXCLUDING SECTION 26 COSTS	\$78,350.00
	SECTION 26 NON PRO-RATEABLE COSTS	
13.	Trucking and landfilling of excavated materials off-site, as follows:	
	a) Station 0+000 to Station 0+065, totalling approximately 10 m ³ of material.	\$1,000.00

Item	Description	Amount
14.	Private access bridge removals, as follows:	
	a) <u>Bridge No. 1 – Station 0+058 (Roll No. 570-48810, Enbridge Gas Ltd.)</u> – Removal and disposal of existing 9.4 m long 900 mm diameter CSP and end wall materials off-site. The work shall include restoring drain channel complete with fine grading and hydro-seeding.	\$2,000.00
15.	Access bridge works, as follows:	
	a) <u>Bridge No. 1A – Station 0+080</u> – Supply and installation of a new 13.5 m long, 600 mm diameter high density polyethylene (HDPE) pipe. Clear stone bedding material beneath pipe, minimum 150 mm thickness (approximately 10 tonnes). Granular 'B' backfill up to pipe springline of pipe (approximately 10 tonnes). Clean native or imported clean native backfill material from springline of pipe culvert to the underside of Granular 'A' driveway material and outside of driveway portion to construct the 0.50 m wide native buffer strips (approximately 25 m ³). Granular 'A' (crushed limestone) compacted driveway surface, minimum 200 mm thickness (approximately 25 tonnes). Sloping stone end walls c/w filter cloth underlay (approximately 20 m ²).	\$6,900.00

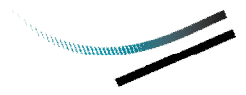

Item	Description	Amount
16.	Private access bridge replacement works, as follows:	
	<p>b) <u>Bridge No. 2 – Station 0+688 (Public Utility, Hydro One Networks Inc.)</u> – Removal and disposal of existing 6.3 m long 600 mm diameter CSP, existing end wall materials and backfill off-site that are not suitable for native backfill. Supply and installation of a new 13 m long, 450 mm diameter high density polyethylene (HDPE) pipe. Clear stone bedding material beneath pipe, minimum 150 mm thickness (approximately 10 tonnes). Granular 'B' backfill up to pipe springline of pipe (approximately 10 tonnes). Clean native or imported clean native backfill material from springline of pipe culvert to the underside of Granular 'A' driveway material and outside of driveway portion to construct the 0.50 m wide native buffer strips (approximately 25 m³). Granular 'A' (crushed limestone) compacted driveway surface, minimum 200 mm thickness (approximately 25 tonnes). Sloping stone end walls c/w filter cloth underlay (approximately 15 m²).</p>	\$7,700.00
17.	Stone erosion protection (SEP) works, as follows:	
	a) Station 0+630 – Supply and place 10 m ² (300 mm thick) of stone erosion protection (SEP) including new filter fabric underlay on the outlet of the private drain on north side of drain.	\$1,600.00
	SUB-TOTAL – SECTION 26 NON PRO-RATEABLE COSTS	\$19,200.00
18.	Engineering cost apportionment	<u>\$9,000.00</u>
	TOTAL – SECTION 26 NON PRO-RATEABLE COSTS	\$28,200.00
	TOTAL ESTIMATE – ANTAYA DRAIN	\$106,550.00

The estimate provided in this report was prepared according to current materials and installation prices as of the date of this report. In the event of delays from the time of filing of the report by the Engineer to the time of tendering the work, it is understood that the estimate of cost is subject to inflation. The rate of inflation shall be calculated using the Consumer Price Index applied to the cost of construction from the date of the report to the date of tendering.

Should the Road Authority elect to construct the drainage works across their road right-of-ways (Section 26.0 increased cost items) with their own forces, as per Section 69 of the Drainage Act, R.S.O., 1990, the Road Authority shall remain responsible for their allotment of costs for the preparation of this report as outlined in our estimate. Should the Road Authority elect not to undertake this work, the work items, as noted under Section 26 above, should be kept separate when tendering out the entire drainage works.

Assessment of Costs

The individual assessments are comprised of three (3) assessment components:

- i. Benefit (advantages relating to the betterment of lands, roads, buildings, or other structures resulting from the improvement to the drain).
- ii. Outlet Liability (part of cost required to provide outlet for lands and roads).
- iii. Special Benefit (additional work or feature that may not affect function of the drain).

We have assessed the estimated costs against the affected lands and roads as listed in Schedule 'C' under "Special Benefit," "Benefit" and "Outlet." Details of the Special Benefit listed in Schedule 'C' are provided in Schedule 'D.'

Assessment Rationale – Open Drain Improvements

In consideration of the previous report (1971 Armstrong), the above estimated costs have been assessed 80% as a Benefit assessment and 20%

as an Outlet Liability assessment against all lands and roads within the drainage areas. Special Benefit assessments shown in Schedule 'C' and detailed in Schedule 'D' were derived as follows:

1. For tile main outlet and lateral tile outlet repairs including stone erosion protection as required, at the location of the said main tile and lateral tile outlets, the Drainage Superintendent and/or Engineer may direct the contractor to make these repairs at the expense of the landowner. Cost associated with these repairs shall be assessed 100% against the property on which the said tile exists.
2. New surface swale inlets and bank failure repairs caused by surface water inlets or private swale drains on abutting lands along the drain shall be assessed 100% against the abutting landowners.
3. All increased costs associated with the drain cleanout from Station 0+000 to Station 0+065 excluding the cost of Bridge No. 1A, shall be assessed against the abutting utilities in accordance with Section 26 of the Drainage Act. This includes 50% of cost assessed to Enbridge Gas Ltd. (Roll No. 570-48810) and the remaining 50% of the cost to Hydro One Networks Inc. (Roll No. 590-00500).
4. Costs associated with the yard catch basin relocation are assessed to the watershed as its current location obstructs the reinstatement of the drain and was not installed within the previous working corridor of the drain.
5. Costs associated with the seeding of the disturbed areas from Station 0+850 and 1+025 shall be assessed against the properties for which seeding is required in an amount proportional to the area affected.

Assessment Rationale for Special Benefit Assessments – Bridge Work

Special Benefit assessment shown in Schedule 'C' and detailed in Schedule 'D' were derived as follows:

1. Costs associated with the removal of Bridge No. 1 have been assessed 100% to Roll No. 570-48810 (Enbridge Gas Ltd.). This bridge does not have status under the Act, and is below the proposed

design grade, and as such it is recommended to for immediate removal.

2. Costs associated with the construction of Bridge No. 1A have been assessed 100% to Roll No. 570-48810 (Enbridge Gas Ltd.) in accordance with Section 26 of the Drainage Act as access is required to complete the recommended work and for future maintenance of the drain between Station 0+000 and Station 0+065.
3. Bridge replacement costs for Bridge No. 2 have been assessed 100% to adjoining property Roll No. 590-00500 (Hydro One Networks Inc.) in accordance with Section 26 of the Drainage Act as this bridge provides continuous access within the Hydro One corridor and its utilities.

Utilities

It may become necessary to temporarily or permanently relocate utilities that may conflict with the construction recommended under this report. In accordance with Section 26 of the Drainage Act, we assess any relocation cost against the public utility having jurisdiction. Under Section 69 of the Drainage Act, the public utility is at liberty to do the work with its own forces, but if it should not exercise this option within a reasonable time, the Town will arrange to have this work completed and the costs will be charged to the appropriate public utility.

Future Maintenance

After completion, the Antaya Drain shall be maintained by the Town of Tecumseh at the expense of the lands and roads herein assessed in Schedule 'E' in the same relative proportions subject, of course, to any variations that may be made under the authority of the Drainage Act. The assessments are based on an arbitrary amount of \$10,000.00.

Future repair and maintenance of Bridge No. 1A shall be assessed 100% to property Roll No. 570-48810 to maintain accessibility to the working corridor between Station 0+000 and Station 0+065. Future repair and maintenance of Bridge No. 2 shall be assessed 100% to property Roll No.

590-00500 to maintain continuity within the Hydro One corridor. All other special benefit assessments for cost items identified herein shall be assessed in same manner for future maintenance and repair costs thereof.

Drawings and Specifications

Attached to this report is Schedule 'F,' which are Specifications setting out the details of the recommended works and Schedule 'G' which represent the drawings that are attached to this report.

- Page 1 of 5: Overall Plan
- Page 2 of 5: Profile 1
- Page 3 of 5: Profile 2 & Cross Sections
- Page 4 of 5: Details
- Page 5 of 5: Bridge Details

Approvals

The construction and/or improvement to a drainage works, including repair and maintenance activities, and all operations connected therewith are subject to the approval, inspection, by-laws and regulations of all Municipal, Provincial, Federal and other authorities having jurisdiction in respect to any matters embraced by the proposed works.

Prior to any construction or maintenance works, the Town or proponent designated on the Town's behalf shall obtain all required approvals/permits and confirm any construction limitations including timing windows, mitigation/off-setting measures, standard practices or any other limitations related to in-stream works.

Grants

In accordance with the provisions of Sections 85, 86 and 87 of the Drainage Act, a grant in the amount of 33-1/3 percent of the assessment eligible for a grant may be made in respect to the assessment made under this report upon privately owned lands used for agricultural purposes. The assessments levied against privately owned agricultural land must also satisfy all other eligibility criteria set out in the Agricultural

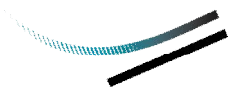

Drainage Infrastructure Program policies. Lands eligible for grant are identified herein Schedule 'C.'

Respectfully submitted,



DILLON CONSULTING LIMITED

Mark D. Hernandez, P.Eng.

MDH:oem:lld

Our File: 17-6818





MEETING MINUTES

Subject: Antaya Drain – Onsite Meeting Minutes
 Date and Time: Thursday, February 8, 2018
 Location: Town of Tecumseh Council Chambers,
 917 Lesperance Rd., Town of Tecumseh
 Our File: 17-6818

Attendees

Mark Hernandez	Dillon Consulting Limited
Sam Paglia	Town of Tecumseh
Sign in sheet attached	

Notes

Item	Discussion	Action By
1.	General Information Regarding The Drainage Act <ul style="list-style-type: none"> • The Drainage Act is a provincial act that is the responsibility of the municipal government to implement • The act is over 100 years old and can be found online by searching Ontario E-Laws • It is a user-based system. • The drainage process can generally be described as follows: <ul style="list-style-type: none"> ○ A request is submitted ○ The Engineer is appointed by the Municipality ○ Site Meetings are held ○ The Report is prepared ○ Public Information Centre (PIC) is held to discuss the draft report with landowners (not required by the Act) ○ Meeting to Consider technical aspects of the report. ○ Court of Revisions to discuss assessments. • The purpose of the site meeting is to provide landowners an opportunity to provide feedback on the current performance of the drain as well as to comment on any changes to the drainage area. 	INFO. INFO. INFO. INFO. INFO.
2.	Assessments <ul style="list-style-type: none"> • Drain Cleanouts <ul style="list-style-type: none"> ○ These costs are assessed for benefit and outlet per the Act. The assessment is based on how much water is sent down the drain and how much of the drain is used by each parcel 	INFO.

- of land.
 - Culvert Replacements
 - When replacement of an existing private access culvert is required, the cost assessment is typically split 50/50. There are exceptions where a public utility may be involved. INFO.
 - If a new culvert is required the landowner is typically assessed 100% of the cost.
 - Special Benefit Assessment
 - These are items that do not affect the function of the drain, these items could include: different headwalls, longer pipes, etc. INFO.
 - The Engineer determines the assessment. The assessment for each property is identified in the report. INFO.
 - Grants are available for properties that have a “Farm Class Tax Rate” INFO.
 - The municipality will bill the landowners after the work is complete for their assessment net of any applicable grant. INFO.
- 3. Report Contents
 - All landowners receive copies of the draft report with their notice for the PIC, meeting to consider and the Court of Revision. INFO.
 - Reports generally Contain:
 - Background information about the request
 - History on the drain
 - Watershed description
 - Design considerations
 - Recommended work
 - Cost estimate
 - Drawings
 - Meeting Minutes
 - Assessments including future maintenance provisions
 - Specifications
- 4. Affects during Construction
 - Typically only landowners along the drain will be affected by construction. INFO.
 - Working corridors are defined within the report. INFO.
 - Work shall result in creating either the same or better level or service.
 - The quality of work is typically monitored during construction by the Drainage Superintendent. Dillon / Tecumseh

- The engineer is required to complete a final inspection.

5. Environmental Requirements
- Often the Department of Fisheries and Oceans, Ministry of Natural Resources and Forestry and the Essex Region Conservation Authority are consulted and a permit may be required. INFO.
6. Next Steps
- Topographical survey will be completed and then the preparation of the report will commence Dillon.
 - PIC meeting will be held to review draft report prior to formal board meetings. INFO.
 - Board Meetings INFO.
7. Discussion
- The landowners identified the following concerns: INFO.
 - The upstream section of the drain from approximately 90 metres north of Wildberry to its south limit has been filled in as part of the residential development in the area.
 - There is very little remaining of the portion of drain behind the homes along Strawberry Drive.
 - It was noted that the landowners along Strawberry Drive are discharging their pool water and some eaves troughs into the Antaya but are not part of the watershed.
 - Based on the above, Dillon will review the appropriate drain extents and drainage area for the Antaya drain as the report is developed. Dillon

Errors and/or Omissions

These minutes were prepared by Kristine Wilkinson EIT who should be notified of any errors and/or omissions.



MEETING MINUTES

Subject: Antaya Drain – PIC Meeting Minutes
 Date and Time: Tuesday, October 26, 2021
 Location: Virtual Meeting, hosted by Town of Tecumseh
 Our File: 17-6818

Attendees

Mark Hernandez	Dillon Consulting Limited (Dillon)
Oliver Moir	Dillon
Sam Paglia	Town of Tecumseh (Town)
Jeff Sylvestre	James Sylvestre Developments Ltd.
Josette Eugeni	James Sylvestre Developments Ltd.
Paul A. Adams	Landowner

Notes

Item	Discussion	Action By
1.	Project Background Presentation <ul style="list-style-type: none"> • Dillon delivered background presentation including: <ul style="list-style-type: none"> – Existing State of Drain – Proposed Improvements & Assessments – Allowances – Working Corridor & Construction 	INFO.
2.	Questions From Landowners <ul style="list-style-type: none"> • Please clarify how the excess soils are to be managed. <ul style="list-style-type: none"> – Excess soils generated from the re-established drain are to be spread across the same land from which the material is removed, and swales are to be created along each property line to ensure existing drainage is maintained. – It is noted that the proposed drainage works are not intended to improve the flooding experienced on each property, but is also not to make any existing flooding worse. The drainage works are only to provide a drain so landowners may have an outlet to discharge to if they decide to make drainage improvements on their own property. • What's to stop residents along Strawberry Drive from reconnecting tiles to the drain? <ul style="list-style-type: none"> – The stormwater for these properties is allocated to the storm sewer along Strawberry Drive and so has not been pulled into 	INFO.

- the watershed for this drainage report. If landowners within the Antaya Drain watershed have concerns with illegal connections to the Antaya Drain, they will have recourse by notifying the Town so the Town may take action through their Building Department to remove subsequent connections.
- During large storm events exceeding the capacity of the Strawberry Drive drainage system, Strawberry Drive lands cannot be held accountable for spilling into the Antaya Drain
 - If Strawberry Drive lands are connected to the watershed, that may alleviate flooding downstream of the drainage system currently receiving Strawberry Drive drainage. INFO.
 - In order to assess this suggestion, a hydrologic and hydraulic assessment would have to be conducted on the existing drainage system of the subdivision.
 - How are landowners supposed to maintain the 1 metre buffer strip along the west side of the drain between Station 0+820 and 1+025? INFO.
 - It was discussed that the west side of the drain is accessible by walking across the drain with smaller equipment (push mower, trimmer, etc) since the drain is less than 3' deep and has 2:1 side slopes. It was discussed that a buffer is necessary as it would not be a good design to have the fences at the top of bank of the reinstated drain.
 - Landowner of Parcel No. 9 has tree lines on both east-west property lines. Will these need to be moved to accommodate the drain or maintenance of the drain? INFO.
 - No. There is sufficient room for the drain and its working corridor.
 - When is construction to occur? INFO.
 - Prior to drain construction, two additional drainage meetings must occur. Following approval of the by-law for the Antaya Drain from Council, the work may be sent out for bidding. If the drain is dry, construction may occur within the fish window (15 March – 15 July, as per DFO). The earliest construction may occur is March 2022.
 - Are grants available for this project? INFO.
 - Only for agricultural lands that are assessed under the Farm Tax rate, not for residential lands.
 - Considering that the Antaya Drain was filled in during the construction of the subdivision and that no maintenance has been completed in 50 years, is it fair that the landowners have to INFO.

pay for the re-establishment of the drain?

- Landowners have the right to request maintenance of the drain. No requests were filed within the last 50 years, and therefore landowners have not paid for maintenance on the Antaya Drain for 50 years. The Drainage Act process has the goal to determine the fairest share of costs, and is completed through public meetings. If a landowner feels their assessment is unfair, they can appeal to the Court of Revision.
- The Town inherited the existing developments and issues from amalgamation. Previous townships likely did not have resources to follow all legislation. The Town is working to rectify issues moving forward using the Drainage Act.
- Property Roll No. 570-48900 is assessed for 8 Acres, but does not drain to the Antaya Drain. A furrow collects water and drains into the East Townline Drain around the Enbridge Gas property. INFO.
- Area assessed was based on previous 1971 report. Dillon will conduct site visit to assess drainage pattern and amend report.
- Property Roll No. 570-48950 is assessed for 9 Acres, but should be assessed 10.92 Acres as the entire property drains to the Antaya Drain. DILLON
- Area assessed was based on previous 1971 report. Dillon will amend report to reflect full area.
- Who pays for the drain repair through Property Roll No. 570-48900 considering the note above? DILLON
- Upstream landowners carry cost because they have a responsibility for the water draining across these lands. Property Roll No. 570-48900 will still have some assessment as the drain still fronts this property, and some runoff will still reach the drain.
- How many meetings are to be held after this PIC? INFO.
- There are two meetings – the Meeting to Consider and the Court of Revision.
- The benefit of having this PIC prior the two legislated meetings is to save time and cost to the project. It is more efficient to work out issues in this meeting than in the future two meetings and there is limited time available with Council.
- Can I have my assessment added to my tax bill? INFO.
- If your assessment is greater than \$4,000, the Town can prorate the assessment over five years. Otherwise, if the assessment is not paid by the due date, it gets put on to the landowner's municipal taxes.

Errors and/or Omissions

These minutes were prepared by Oliver Moir, EIT who should be notified of any errors and/or omissions.

"SCHEDULE B"
SCHEDULE OF ALLOWANCES
ANTAYA DRAIN
TOWN OF TECUMSEH

Roll No.	Con.	Description	Owner	Section 30 Damages	Section 29 Land	Total Allowances
570-01800	3	Pt. Lot 152	Paul A. Adams	\$0.00	\$74.00	\$74.00
570-01900	3	Pt. Lot 152	Daniel R. Beaulieu	\$0.00	\$74.00	\$74.00
570-02000	3	Pt. Lot 152	Lehmber S. & Kulwant K. Pahal	\$0.00	\$74.00	\$74.00
570-02100	3	Pt. Lot 152	Mary A. Lee	\$0.00	\$74.00	\$74.00
570-02200	3	Pt. Lot 152	Brian & Karen Rutherford	\$0.00	\$74.00	\$74.00
570-02300	3	Pt. Lot 152	Blaze, Anka & Ljubica Ristovski	\$0.00	\$74.00	\$74.00
570-02400	3	Pt. Lot 152	Carole Kitching	\$0.00	\$74.00	\$74.00
570-02500	3	Pt. Lot 152	Marie A. Gagnier	\$0.00	\$74.00	\$74.00
570-02600	3	Pt. Lot 152	Farina G. Keufuss	\$0.00	\$74.00	\$74.00
570-48900	3	Pt. Lot 156	James Sylvestre Developments Ltd.	\$1,145.00	\$0.00	\$1,145.00
570-48950	3	Pt. Lot 153	James Sylvestre Developments Ltd.	\$935.00	\$0.00	\$935.00
590-00500			Hydro One Networks Inc.	\$1,620.00	\$3,334.00	\$4,954.00
TOTAL ALLOWANCES				\$3,700.00	\$4,000.00	\$7,700.00

"SCHEDULE C"
SCHEDULE OF ASSESSMENT (REVISED)
ANTAYA DRAIN
TOWN OF TECUMSEH

PRIVATELY-OWNED - NON-AGRICULTURAL LANDS:

Roll No.	Con.	Description	Area Affected		Owner	Special Benefit	Benefit	Outlet	Total Assessment
			(Acres)	(Ha.)					
570-01800	3	Pt. Lot 152	0.50	0.20	Paul A. Adams	\$1,824.00	\$1,147.00	\$423.00	\$3,394.00
570-01900	3	Pt. Lot 152	0.50	0.20	Daniel R. Beaulieu	\$2,117.00	\$1,147.00	\$417.00	\$3,681.00
570-02000	3	Pt. Lot 152	0.50	0.20	Lehmer S. & Kulwant K. Pahal	\$2,117.00	\$1,147.00	\$413.00	\$3,677.00
570-02100	3	Pt. Lot 152	0.50	0.20	Mary A. Lee	\$2,117.00	\$1,147.00	\$408.00	\$3,672.00
570-02200	3	Pt. Lot 152	0.50	0.20	Brian & Karen Rutherford	\$1,553.00	\$1,147.00	\$404.00	\$3,104.00
570-02300	3	Pt. Lot 152	0.50	0.20	Blaze, Anka & Ljubica Ristovski	\$1,164.00	\$1,147.00	\$400.00	\$2,711.00
570-02400	3	Pt. Lot 152	0.50	0.20	Carole Kitching	\$1,164.00	\$1,147.00	\$394.00	\$2,705.00
570-02500	3	Pt. Lot 152	0.50	0.20	Marie A. Gagnier	\$615.00	\$1,147.00	\$389.00	\$2,151.00
570-02600	3	Pt. Lot 152	0.50	0.20	Farina G. Keuhfuss	\$0.00	\$1,147.00	\$385.00	\$1,532.00
570-03100	3	Pt. Lots 152 & 153	4.36	1.76 *	Brian J. Berry	\$0.00	\$5,151.00	\$949.00	\$6,100.00
570-48810	3	Pt. Lot 156	0.59	0.24	Enbridge Gas Ltd.	\$0.00	\$3,034.00	\$897.00	\$3,931.00
590-00500	3	Pt. Lot 152, 153 & 156	12.11	4.90	Hydro One Networks Inc.	\$0.00	\$18,942.00	\$3,663.00	\$22,605.00
PIN 75329-0156	3	Pt. Lot 152	0.22	0.09	James Sylvestre Developments Ltd.	\$0.00	\$380.00	\$190.00	\$570.00
Total on Privately-Owned - Non-Agricultural Lands.....						\$12,671.00	\$37,830.00	\$9,332.00	\$59,833.00

PRIVATELY-OWNED - AGRICULTURAL LANDS (GRANTABLE)

Roll No.	Con.	Description	Area Affected		Owner	Special Benefit	Benefit	Outlet	Total Assessment
			(Acres)	(Ha.)					
570-48900	3	Pt. Lot 156	1.51	0.61	James Sylvestre Developments Ltd.	\$0.00	\$1,643.00	\$430.00	\$2,073.00
570-48950	3	Pt. Lot 153	10.29	4.16	James Sylvestre Developments Ltd.	\$2,197.00	\$11,313.00	\$2,934.00	\$16,444.00
Total on Privately-Owned - Agricultural Lands (Grantable).....						\$2,197.00	\$12,956.00	\$3,364.00	\$18,517.00

SECTION 26 & NON-AGRICULTURAL LANDS (NON PRO-RATABLE)

Roll No.	Con.	Description	Owner	Special Benefit	Benefit	Outlet	Total Assessment
Public Utility			Hydro One Networks Inc.	\$14,394.00	\$0.00	\$0.00	\$14,394.00
Total Section 26 & Non-Agricultural Lands (Non Pro-ratable).....				\$28,200.00	\$0.00	\$0.00	\$28,200.00

TOTAL ASSESSMENT					\$43,068.00	\$50,786.00	\$12,696.00	\$106,550.00
			(Acres)	(Ha.)				
		Total Area:	33.58	13.56				

* DENOTES PARTIAL AREA COVERED BY EXISTING WOODLOT AND REDUCED ASSESSMENT

"SCHEDULE D"
DETAILS OF SPECIAL BENEFIT (REVISED)
ANTAYA DRAIN
TOWN OF TECUMSEH
SPECIAL BENEFIT ASSESSMENT
(NON - AGRICULTURAL LANDS)

Roll No.	Owner	Item Description	Estimated Cost	Cost of Report	Special Benefit
570-01800	Paul A. Adams	Supply and installation of stone erosion protection on surface swale outlet (Station 1+006) (50%)	\$200.00	\$93.00	\$293.00
		Broadcast seed area west of top of bank disturbed from spreading and levelling of excavated material (19%).	\$1,045.00	\$486.00	\$1,531.00
		Total Special Benefit - Roll No. 570-01800	\$1,245.00	\$579.00	\$1,824.00
570-01900	Daniel R. Beaulieu	Supply and installation of stone erosion protection on surface swale outlets (Stations 1+006 & 0+983) (50%)	\$400.00	\$186.00	\$586.00
		Broadcast seed area west of top of bank disturbed from spreading and levelling of excavated material (19%).	\$1,045.00	\$486.00	\$1,531.00
		Total Special Benefit - Roll No. 570-01900	\$1,445.00	\$672.00	\$2,117.00
570-02000	Lehmer S. & Kulwant K. Pahal	Supply and installation of stone erosion protection on surface swale outlets (Stations 0+983 & 0+961) (50%)	\$400.00	\$186.00	\$586.00
		Broadcast seed area west of top of bank disturbed from spreading and levelling of excavated material (19%).	\$1,045.00	\$486.00	\$1,531.00
		Total Special Benefit - Roll No. 570-02000	\$1,445.00	\$672.00	\$2,117.00
570-02100	Mary A. Lee	Supply and installation of stone erosion protection on surface swale outlets (Stations 0+961 & 0+938) (50%)	\$400.00	\$186.00	\$586.00
		Broadcast seed area west of top of bank disturbed from spreading and levelling of excavated material (19%).	\$1,045.00	\$486.00	\$1,531.00
		Total Special Benefit - Roll No. 570-02100	\$1,445.00	\$672.00	\$2,117.00
570-02200	Brian & Karen Rutherford	Supply and installation of stone erosion protection on surface swale outlets (Stations 0+938 & 0+919) (50%)	\$400.00	\$186.00	\$586.00
		Broadcast seed area west of top of bank disturbed from spreading and levelling of excavated material (12%).	\$660.00	\$307.00	\$967.00
		Total Special Benefit - Roll No. 570-02200	\$1,060.00	\$493.00	\$1,553.00
570-02300	Blaze, Anka & Ljubica Ristovski	Supply and installation of stone erosion protection on surface swale outlets (Stations 0+919 & 0+890) (50%)	\$575.00	\$267.00	\$842.00
		Broadcast seed area west of top of bank disturbed from spreading and levelling of excavated material (4%).	\$220.00	\$102.00	\$322.00
		Total Special Benefit - Roll No. 570-02300	\$795.00	\$369.00	\$1,164.00
570-02400	Carol Kitching	Supply and installation of stone erosion protection on surface swale outlets (Stations 0+890 & 0+868) (50%)	\$575.00	\$267.00	\$842.00
		Broadcast seed area west of top of bank disturbed from spreading and levelling of excavated material (4%).	\$220.00	\$102.00	\$322.00
		Total Special Benefit - Roll No. 570-02400	\$795.00	\$369.00	\$1,164.00

Roll No.	Owner	Item Description	Estimated Cost	Cost of Report	Special Benefit
570-02500	Marie A. Gagnier	Supply and installation of stone erosion protection on surface swale outlets (Station 0+868) (50%)	\$200.00	\$93.00	\$293.00
		Broadcast seed area west of top of bank disturbed from spreading and levelling of excavated material (4%).	\$220.00	\$102.00	\$322.00
Total Special Benefit - Roll No. 570-02500			\$420.00	\$195.00	\$615.00
Total Special Benefit Assessment (Non - Agricultural Lands).....			\$8,650.00	\$4,021.00	\$12,671.00

SPECIAL BENEFIT ASSESSMENT
(AGRICULTURAL LANDS)

Roll No.	Owner	Item Description	Estimated Cost	Cost of Report	Special Benefit
570-48950	James Sylvestre Developments Ltd.	Supply and installation of stone erosion protection with filter fabric underlay on surface swale outlet (south bank at Station 0+415) (100%)	\$1,500.00	\$697.00	\$2,197.00
Total Special Benefit Assessment (Agricultural Lands).....			\$1,500.00	\$697.00	\$2,197.00

SPECIAL BENEFIT ASSESSMENT
(SECTION 26 & NON - AGRICULTURAL LANDS NON PRO-RATABLE)

Roll No.	Owner	Item Description	Estimated Cost	Cost of Report	Special Benefit
570-48810	Enbridge Gas Ltd.	Trucking and landfilling of excavated material from Station 0+000 to Station 0+065 (50%)	\$500.00	\$234.00	\$734.00
		<u>Bridge No. 1</u> - Removal of existing 9.3 m long 900 mm diameter culvert (100%)	\$2,000.00	\$938.00	\$2,938.00
		<u>Bridge No. 1A</u> - Supply and install 13.5 m long 600 mm diameter HDPE culvert, including specified backfill material (100%).	\$6,900.00	\$3,234.00	\$10,134.00
Total Special Benefit - Roll No. 570-48810			\$9,400.00	\$4,406.00	\$13,806.00
590-00500	Hydro One Networks Inc.	Trucking of excavated material from Station 0+000 to Station 0+065 (50%)	\$500.00	\$234.00	\$734.00
		<u>Bridge No. 2</u> - Removal of existing culvert and replace with new 13 m long 450 mm diameter HDPE culvert, including specified backfill material (100%).	\$7,700.00	\$3,610.00	\$11,310.00
		Supply and installation of stone erosion protection with filter fabric underlay on surface swale outlet (north bank at Station 0+630) (100%)	\$1,600.00	\$750.00	\$2,350.00
Total Special Benefit - Roll No. 590-00500			\$9,800.00	\$4,594.00	\$14,394.00
Total Special Benefit Assessment (Section 26 & Non-Agricultural Lands Non Pro-Ratable)			\$19,200.00	\$9,000.00	\$28,200.00
OVERALL TOTAL SPECIAL BENEFIT ASSESSMENT					\$43,068.00

"SCHEDULE E"
SCHEDULE OF ASSESSMENT FOR FUTURE MAINTENANCE (DRAIN) (REVISED)
ANTAYA DRAIN
TOWN OF TECUMSEH

PRIVATELY-OWNED - NON-AGRICULTURAL LANDS:

Roll No.	Con.	Description	Area Affected		Owner	Special Benefit	Benefit	Outlet	Total Assessment
			(Acres)	(Ha.)					
570-01800	3	Pt. Lot 152	0.50	0.20	Paul A. Adams	\$0.00	\$181.00	\$67.00	\$248.00
570-01900	3	Pt. Lot 152	0.50	0.20	Daniel R. Beaulieu	\$0.00	\$181.00	\$66.00	\$247.00
570-02000	3	Pt. Lot 152	0.50	0.20	Lehmer S. & Kulwant K. Pahal	\$0.00	\$181.00	\$65.00	\$246.00
570-02100	3	Pt. Lot 152	0.50	0.20	Mary A. Lee	\$0.00	\$181.00	\$64.00	\$245.00
570-02200	3	Pt. Lot 152	0.50	0.20	Brian & Karen Rutherford	\$0.00	\$181.00	\$64.00	\$245.00
570-02300	3	Pt. Lot 152	0.50	0.20	Blaze, Anka & Ljubica Ristovski	\$0.00	\$181.00	\$63.00	\$244.00
570-02400	3	Pt. Lot 152	0.50	0.20	Carole Kitching	\$0.00	\$181.00	\$62.00	\$243.00
570-02500	3	Pt. Lot 152	0.50	0.20	Marie A. Gagnier	\$0.00	\$181.00	\$61.00	\$242.00
570-02600	3	Pt. Lot 152	0.50	0.20	Farina G. Keuhfuss	\$0.00	\$181.00	\$61.00	\$242.00
570-03100	3	Pt. Lots 152 & 153	4.36	1.76	Brian J. Berry	\$0.00	\$811.00	\$150.00	\$961.00
570-48810	3	Pt. Lot 156	0.59	0.24	Enbridge Gas Ltd.	\$0.00	\$478.00	\$141.00	\$619.00
590-00500	3	Pt. Lot 152, 153 & 156	12.11	4.90	Hydro One Networks Inc.	\$0.00	\$2,984.00	\$578.00	\$3,562.00
PIN 75329-0156	3	Pt. Lot 152	0.22	0.09	James Sylvestre Developments Ltd.	\$0.00	\$60.00	\$30.00	\$90.00
Total on Privately-Owned - Non-Agricultural Lands.....						\$0.00	\$5,962.00	\$1,472.00	\$7,434.00

PRIVATELY-OWNED - AGRICULTURAL LANDS (GRANTABLE)

Roll No.	Con.	Description	Area Affected		Owner	Special Benefit	Benefit	Outlet	Total Assessment
			(Acres)	(Ha.)					
570-48900	3	Pt. Lot 156	1.51	0.61	James Sylvestre Developments Ltd.	\$0.00	\$259.00	\$68.00	\$327.00
570-48950	3	Pt. Lot 153	10.29	4.16	James Sylvestre Developments Ltd.	\$0.00	\$1,779.00	\$460.00	\$2,239.00
Total on Privately-Owned - Agricultural Lands (Grantable).....						\$0.00	\$2,038.00	\$528.00	\$2,566.00

TOTAL ASSESSMENT						\$0.00	\$8,000.00	\$2,000.00	\$10,000.00
			(Acres)	(Ha.)					
Total Area:			33.58	13.56					

"SCHEDULE F"
DRAINAGE REPORT FOR THE
ANTAYA DRAIN
TOWN OF TECUMSEH

SPECIAL PROVISIONS - GENERAL

1.0 GENERAL SPECIFICATIONS

The General Specifications attached hereto is part of "Schedule F." It also forms part of this specification and is to be read with it, but where there is a difference between the requirements of the General Specifications and those of the Special Provisions which follow, the Special Provisions will take precedence.

2.0 DESCRIPTION OF WORK

The work to be carried out under this Contract includes, but is not limited to, the supply of all labour, equipment and materials to complete the following items:

Open Drain Work

- Brushing of the drain from Station 0+000 to Station 0+920 including the disposal by burning on-site or removal off-site with trimming and/or removal of existing trees as required to accommodate the drainage works. Work includes trimming of branches overhanging the drain, and cut and removal of mature trees within the limits of drain banks.
- Excavation and levelling of excavated materials works, as follows:
 - Excavation of the drain bottom only from Station 0+000 to Station 0+850, totalling approximately 850 lineal metres of drain and approximately 200 m³ of material, including spreading and levelling 190 m³ within the working corridor between Station 0+065 and Station 0+850.
 - Excavation of the drain bottom only from Station 0+850 to Station 0+920, totalling 70 lineal metres of drain and approximately 20 m³ of material.

- Excavation of new drain from Station 0+920 to Station 1+025, totalling approximately 105 lineal metres of drain and approximately 190 m³ of material.
 - Spreading of excavated material originating from the drain from Station 0+850 and 1+025 to a maximum of 100 mm thickness (approximately 210 m³) over lands fronting westerly drain bank. Work includes forming of swale graded towards drain at each property line.
 - Strip and salvage topsoil of full depth (minimum 100 mm thickness) from footprint of the new drain from Station 0+920 to Station 1+025. Work includes placement and fine grading of salvaged topsoil over the new drain banks at a minimum 50 mm thickness (approximately 25 m²). Topsoil material without deleterious material, subject to approval by the Drainage Superintendent, shall be stockpiled within the designated working corridor and kept as far as possible from the drain top of bank. Stockpiled topsoil shall be contained with sediment erosion control and kept separate from other drain excavation materials for future use.
 - Strip, salvage, restore, and fine grade topsoil, a minimum 100 mm depth and approximately 20 metres wide off of westerly top of bank from Station 0+850 to Station 1+025. Topsoil material without deleterious material, subject to approval by the Drainage Superintendent, shall be stockpiled within the property limits of which it originated. Stockpiled topsoil shall be contained with sediment erosion control and kept separate from other drain excavation materials for future use.
- Hydraulic seeding of new drain banks from Station 0+850 to Station 1+025 (approximately 470 m²).
 - Broadcast seeding of area west of top of bank from Station 0+850 to Station 1+025 approximately 20 metres wide (approximately 2,060 m²).

- Stone erosion protection (SEP) works, as follows:
 - Station 0+415 – Supply and place 15 m² (300 mm thick) of stone erosion protection (SEP) including new filter fabric underlay on the outlet of the private swale drain to repair bank failure on the south side of the drain.
 - Station 0+868 – Supply and place 4 m² (300 mm thick) of stone erosion protection (SEP) including new filter fabric underlay on the outlet of new private swale drain outlet on the west side of the drain.
 - Station 0+890 – Supply and place 7 m² (300 mm thick) of stone erosion protection (SEP) including new filter fabric underlay on the outlet of the private swale drain to repair bank failure on the west side of the drain.
 - Station 0+919 – Supply and place 4 m² (300 mm thick) of stone erosion protection (SEP) including new filter fabric underlay on the outlet of the private swale drain to repair bank failure on the west side of the drain.
 - Station 0+938 – Supply and place 4 m² (300 mm thick) of stone erosion protection (SEP) including new filter fabric underlay on the outlet of new private swale drain outlet on the west side of the drain.
 - Station 0+961 – Supply and place 4 m² (300 mm thick) of stone erosion protection (SEP) including new filter fabric underlay on the outlet of new private swale drain outlet on the west side of the drain.
 - Station 0+983 – Supply and place 4 m² (300 mm thick) of stone erosion protection (SEP) including new filter fabric underlay on the outlet of new private swale drain outlet on the west side of the drain.
 - Station 1+006 – Supply and place 4 m² (300 mm thick) of stone erosion protection (SEP) including new filter fabric underlay on the outlet of new private swale drain outlet on the west side of the drain.

- Remove and dispose of existing yard catch basin (YCB) at Station 0+983. Supply and install new 450 mm diameter high density polyethylene (HDPE) YCB 2 m west of current location, complete with cast iron grate and 'Big-O' leader pipe to new drain. Work includes reconnecting existing inlets, re-grading of land toward CB, and fine grading and re-seeding disturbed areas.
- Temporary Silt Control Measures During Construction
- Trucking and landfilling of excavated materials off-site, as follows:
 - Station 0+000 to Station 0+065, totalling approximately 10 m³ of material.
- Private access bridge removals, as follows:
 - Bridge No. 1 – Station 0+058 (Roll No. 570-48810, Enbridge Gas Ltd.) – Removal and disposal of existing 9.4 m long 900 mm diameter CSP and end wall materials off-site. The work shall include restoring drain channel complete with fine grading and hydro-seeding.
- Access bridge works, as follows:
 - Bridge No. 1A – Station 0+080 – Supply and installation of a new 13.5 m long, 600 mm diameter high density polyethylene (HDPE) pipe. Clear stone bedding material beneath pipe, minimum 150 mm thickness (approximately 10 tonnes). Granular 'B' backfill up to pipe springline of pipe (approximately 10 tonnes). Clean native or imported clean native backfill material from springline of pipe culvert to the underside of Granular 'A' driveway material and outside of driveway portion to construct the 0.50 m wide native buffer strips (approximately 25 m³). Granular 'A' (crushed limestone) compacted driveway surface, minimum 200 mm thickness (approximately 25 tonnes). Sloping stone end walls c/w filter cloth underlay (approximately 20 m²).

- Private access bridge replacement works, as follows:
 - Bridge No. 2 – Station 0+688 (Public Utility, Hydro One Networks Inc.) – Removal and disposal of existing 6.3 m long 600 mm diameter CSP, existing end wall materials and backfill off-site that are not suitable for native backfill. Supply and installation of a new 13 m long, 450 mm diameter high density polyethylene (HDPE) pipe. Clear stone bedding material beneath pipe, minimum 150 mm thickness (approximately 10 tonnes). Granular 'B' backfill up to pipe springline of pipe (approximately 10 tonnes). Clean native or imported clean native backfill material from springline of pipe culvert to the underside of Granular 'A' driveway material and outside of driveway portion to construct the 0.50 m wide native buffer strips (approximately 25 m³). Granular 'A' (crushed limestone) compacted driveway surface, minimum 200 mm thickness (approximately 25 tonnes). Sloping stone end walls c/w filter cloth underlay (approximately 15 m²).
- Stone erosion protection (SEP) works, as follows:
 - Station 0+630 – Supply and place 10 m² (300 mm thick) of stone erosion protection (SEP) including new filter fabric underlay on the outlet of the private drain on north side of drain.

3.0 ACCESS TO THE WORK

Access to the drain shall be from Manning Road (County Road No. 19), using the farm access to the property owned by Hydro One Networks Inc. (Roll No. 590-00500). The maximum width of the access corridor on Hydro One lands shall be 6 metres and confined to the southerly limit of the property. This access shall be used for both drain improvements and future maintenance of the Antaya Drain from Station 0+000 to Station 1+025. The Contractor shall make his/her own arrangements for any additional access for his/her convenience. All road areas and grass lawn areas disturbed shall be restored to original conditions at the Contractor's expense.

4.0 WORKING AREA

The Contractor shall restrict his equipment to the working corridors as specified in this Section. Any damage resulting from non-compliance with this Section shall be borne by the Contractor. The working corridor shall be measured from the top of the drain bank and shall be as follows:

FROM STA.	TO STA.	PRIMARY (See Note 1)	SECONDARY (See Note 2)
0+000	0+080	9.0 m wide on north side of drain*	N/A
0+065	0+385	9.0 m wide on south side of drain	N/A
0+385	0+408	9.0 m wide on east side of drain	N/A
0+408	0+630	9.0 m wide on south side of drain	N/A
0+630	0+850	9.0 m wide on east side of drain	6.0 m wide on west side of drain*
0+850	1+025	6.0 m wide on west side of drain*	N/A

*Note: Indicates new working corridor specified under this report.

Note 1: Primary working corridor indicates the access corridor along the side of the drain where excavation and levelling is recommended (unless noted otherwise below and/or in the Specifications, as well as all purposes listed for Secondary Working Corridors).

Note 2: Secondary working corridor indicates the access corridor alongside the drain where construction equipment may travel for the purpose of trucking, drain bank repairs, tile inlet repairs, surface water inlet repairs, grass buffer strips and other miscellaneous works. No disposal of fill or levelling of materials shall be permitted within a secondary working corridor. As further specified, use of this secondary working corridor may be further restricted due to site condition. Read all Specifications, Drawings and/or notes before completing works.

Note 3: The trucking required within the working corridor shall be confined to the north side of the drain from Station 0+000 to Station 0+080; to the west side of the drain from Station 0+688 to Station 1+025; and to the east side of the drain from Station 0+630 to Station 0+820. Beyond Station 0+820, the 6 m wide access corridor defined along the south limit of the Hydro One corridor shall be used for equipment access, delivery of construction materials and trucking route for dispersal of excavated materials.

SPECIAL PROVISIONS – OPEN DRAIN

5.0 BRUSHING

Brushing shall be carried out on the entire drain within the above identified sections of the drain where required and as specified herein. All brush and trees located within the drain side slopes shall be cut parallel to the side slopes, as close to the ground as practicable. This includes at least one mature tree within the banks of the drain between Station 0+408 and Station 0+630. Tree branches that overhang the drain shall be trimmed. Small branches and limbs are to be disposed of by the Contractor along with the other brush. Tree stumps, where removed to facilitate the drain excavation and reshaping of the drain banks, may be burned by the Contractor where permitted; otherwise, they shall be disposed of, off the site. The Contractor shall make every effort to preserve mature trees which are beyond the drain side slopes, and the working corridors. If requested to do so by the Drainage Superintendent, the Contractor shall preserve certain mature trees within the designated working corridors (see Section 4.0).

Except as specified herein, all brush and trees shall be stockpiled adjacent to the drain within the working corridors. Stockpiles shall not be less than 100 m apart and shall be a minimum of 2.0 m from the edge of the drain bank. All brush, timber, logs, stumps, large stones or other obstructions and deleterious materials that interfere with the construction of the drain, as encountered along the course of the drain are to be removed from the drain by the Contractor. Large stones and other similar material shall be disposed of by the Contractor off the site. Following completion of the work, the Contractor is to trim up any broken or damaged limbs on trees which remain standing, disposing of the branches cut off along with other brush and leaving the trees in a neat and tidy condition.

Brush and trees removed from the working area are to be put into piles by the Contractor, in locations where they can be safely burned, and to be burned by the Contractor after obtaining the necessary permits, as required. If, in the opinion of the Drainage Superintendent, any of the piles are too wet or green to be burned, he shall so advise the Contractor to haul away the unburned materials to an approved dump site. Prior to, and during the course of burning operations, the Contractor shall comply with the current guidelines prepared by the Air Quality Branch of the Ontario Ministry of Environment, Conservation and Parks shall ensure that the Environmental Protection Act is not violated. Since the trees and brush that are cut off flush with the earth surface may sprout new growth later, it is strongly recommended that the Town make arrangements for spraying this new growth at the appropriate time so as to kill the trees and brush.

As part of this work, the Contractor shall remove any loose timber, logs, stumps, large stones or other debris from the drain bottom and from the side slopes. Timber, logs, stumps, large stones or other debris shall be disposed of off-site.

6.0 EXCAVATION AND LEVELLING OF EXCAVATED MATERIALS

6.1 Alignment of Reinstated Drain

The centerline of the drain section to be reinstated between Station 0+920 and Station 1+025 shall be kept parallel with the line between Lot 152 and Lot 153, offset 4 metres west, maintaining a minimum of 1 metre from the top of east back to said lot line. The drain shall terminate on the southerly limit of property Roll No. 570-01800.

6.2 Excavation of Existing and New Drain Channel

In all cases, the Contractor shall use the benchmarks to establish the proposed grade. However, for convenience, the drawings provide the approximate depth from the surface of the ground and from the existing drain bottom to the proposed grades. The Contractor shall not excavate deeper than the gradelines shown on the Drawings.

Should over-excavation of the drain bank occur, the Contractor will not be permitted to repair with native material packed into place by the excavator and reshaped. Should over-excavation occur, the Contractor will be required to have a bank repair detail engineered by a Professional Engineer (hired by the

Contractor), to ensure long term stability of the bank is maintained. Such repairs shall be subject to approval by the Engineer and will be at no extra cost to the item.

All excavated material shall be handled as specified in Section 6.3. Materials deposited on the farmlands shall be within the working corridors, at least 1.0 m from the top of the drain bank, or as specified on the drawings. Upon allowing drying of excavated materials (if necessary) and as approved by the Drainage Superintendent, the Contractor shall level excavated materials in accordance with Section 6.3. Excavated material shall not be placed on dykes, in ditches, tiles or depressions intended to conduct water into the drain.

Seeding of the disturbed drain banks shall be completed immediately following drain construction and as specified in Section 9.0.

All excavation work shall be done in such a manner as to not harm any vegetation or trees, not identified in this report or by the Drainage Superintendent for clearing. Any damages to trees or vegetation caused by the Contractors work shall be rectified to the satisfaction of the Drainage Superintendent.

The Contractor shall exercise caution around existing tile inlets and shall confirm with the property owners that all tiles have been located and tile ends repaired as specified.

6.3 Levelling of Excavated Materials

Excavation of the drain bottom shall be completed as specified in Section 6.1, above and also as specified below and as shown on the drawings.

Excavated drain materials shall be spread to a depth not to exceed 300 mm, unless specified otherwise on the drawings. The material shall be sufficiently levelled to allow further working by agricultural implements. All stones and other debris removed from the drain, which may interfere with agricultural implements, shall be disposed of off-site. Excavated material shall not be placed on dykes, in ditches, tiles or depressions intended to conduct water into the drain.

6.4 Trucking of Excavated Materials

The Contractor shall be solely responsible for acquiring all permits required from the Town of Tecumseh prior to hauling any fill materials off-site. The Contractor's attention is brought to the Excess Soils Regulation O. Reg 416/19 and the responsibilities of the Contractor thereunder.

The Contractor shall restore any such areas which are damaged by his operations, to original or better condition. The Contractor will be held liable for damages to roads, sodded areas and gardens, resulting from his non-compliance with these specifications.

7.0 DRAIN EXCAVATION WORK (STA. 0+000 TO STA. 0+065)

High pressure gas main crossings may exist underneath the Antaya Drain between Station 0+000 and Station 0+065. The Contractor is responsible for utility locates prior to construction and to provide Enbridge Gas Ltd. a minimum 48 hours advanced notice for arranged third party inspection.

8.0 STONE EROSION PROTECTION (SEP)

The Contractor shall supply and install the required quantities of graded stone rip-rap erosion protection materials where specified. All stone to be used for erosion protection shall be 125 - 250 mm clear quarried rock or OPSS 1001 placed over a non-woven filter fabric Terrafix 270R or approved equivalent. Concrete rip-rap will not be permitted.

The minimum thickness requirement of the erosion stone layer is 300 mm with no portion of the filter fabric to be exposed.

9.0 SEEDING OF DRAIN BANKS & RESTORATION OF GRASSED AREAS

All existing grassed areas disturbed by construction and newly excavated drain banks shall either be hydraulic mulch seeded broadcast seeded if soil conditions warrant, as specified herein. The existing ground surface to be seeded shall be loosened to a depth of 25 mm and shall be rendered uniformly loose for that 25 mm depth. The surface shall be predominantly fine and free from weeds and other unwanted vegetation.

All other loose surface litter shall be removed and disposed of. For the restoration of the existing grassed lawns for the portion of drain between Station 0+850 and Station 1+025, a minimum 100 mm layer of screened topsoil to be provided and fine graded prior to seeding.

Hydraulic mulch shall consist of finely ground cellulose pulp derived from recycled newsprint and shall be dyed green. Its fiber consistency shall be approximately 60% fine fiber with the balance being paper particles, 40% of which shall be a diameter of 3 mm minimum and 6 mm maximum.

Hydraulic mulch shall be applied at 2,000 kg per 10,000 m². Clean water shall be applied at 42,700 liters per 10,000 m².

Seeding and mulching shall be a one step process in which the seed, fertilizer and hydraulic mulch are applied simultaneously in a water slurry via the hydraulic seeder/mulcher. The materials shall be added to the supply tank while it is being loaded with water. The materials shall be thoroughly mixed into a homogeneous water slurry and shall be distributed uniformly over the prepared surface. The materials shall be measured by mass or by a mass-calibrated volume measurement, acceptable to the Drainage Superintendent.

The hydraulic seeder/mulcher shall be equipped with mechanical agitation equipment capable of mixing the materials into a homogenous state until applied. The discharge pumps and gun nozzles shall be capable of applying the material uniformly.

Grass seed shall be Canada No. 1 grass seed mixture meeting the requirements of a Waterway Slough Mixture as supplied by Growmark or approved equal, as follows:

Creeping Red Fescue	20%
Meadow Fescue	30%
Tall Fescue	30%
Timothy	10%
White Clover	10%

Bags shall bear the label of the supplier indicating the content by species, grade and mass. Seed shall be applied at a rate of 200 kg per 10,000 m².

Fertilizer shall be 8-32-16 applied at 350 kg per 10,000 m².

It shall be in granular form, dry, free from lumps and in bags bearing the label of the manufacturer, indicating mass and analysis.

The hydraulic seeding shall be deemed "Completed by the Contractor" when the seed has established in all areas to the satisfaction of the Engineer. Re-seeding and/or other methods required to establish the grass will be given consideration to achieve the end result and the costs shall be incidental to the works.

10.0 ACCESS BRIDGE WORK

10.1 Location of New Culvert

The new culverts shall be installed as shown on the drawings attached hereto. The centerline of the new culvert for Bridge No. 1A shall be located to align itself with the existing centerline of the drain. The centerline of the new culvert for Bridge No. 2 shall be located to align itself with the existing access bridge (Roll No. 590-00500).

10.2 Removal of Existing Culverts

The Contractor shall exercise caution when removing these materials as to minimize damage to the drain banks. Any damage to the drain shall be restored to original conditions at the expense of the Contractor. The removed materials (existing culvert debris and end wall materials) shall be hauled away off-site.

10.3 Materials for New Access Bridges

Materials shall be as follows:

Culvert Pipe

Bridge No. 1A - Station 0+080: 13.5 m long, 600 mm diameter solid (non-perforated) corrugated High Density Polyethylene (H.D.P.E.) smooth wall interior (Armtec Boss 2000 or approved equivalent) unless otherwise specified conforming to the following specifications: ASTM @3350, CSA B182.8-02 and OPSS 1840. The pipe is to provide a minimum pipe stiffness of 320 kPa.

Joined using (soil tight) "split" coupler joining system (Split couplers manufactured by Armtec Limited or approved equal), supplied by the pipe manufacturer and conforming to ASTM D3350, CSA 182.8-02 and OPSS 1840. Joints wrapped in "Non-Woven" geotextile filter fabric with a minimum strength equal to or greater than Terrafix 270R, Amoco 446, Mirafi 140NC or approved equivalent.

Bridge No. 2 - Station 0+688: New 13.0 m long, 450 mm diameter solid (non-perforated) corrugated High Density Polyethylene (H.D.P.E.) smooth wall interior (Armtec Boss 2000 or approved equivalent) unless otherwise specified conforming to the following specifications: ASTM @3350, CSA B182.8-02 and OPSS 1840. The pipe is to provide a minimum pipe stiffness of 320 kPa. Joined using (soil tight) "split" coupler joining system (Split couplers manufactured by Armtec Limited or approved equal), supplied by the pipe manufacturer and conforming to ASTM D3350, CSA 182.8-02 and OPSS 1840. Joints wrapped in "Non-Woven" geotextile filter fabric with a minimum strength equal to or greater than Terrafix 270R, Amoco 446, Mirafi 140NC or approved equivalent.

Pipe Bedding Below Pipe

20-25 mm clear stone conforming to OPSS Division 10.

Backfill up to Pipe Culvert Springline

Granular 'B' conforming to OPSS Division 10.

Backfill above Pipe Springline up to Bottom of Driveway Surface Materials

Dry native material free of topsoil, organic matter, broken concrete, steel, wood and deleterious substances. Alternatively, Granular 'A' or 'B' conforming to OPSS Division 10.

Driveway Surface

Granular 'A' made from crushed limestone conforming to OPSS Division 10. Minimum 200 mm thickness.

Erosion Stone

All stone to be used for erosion protection shall be 125 - 250 mm clear quarried rock or OPSS 1004, minimum 300 mm thickness.

Buffer Strips

Dry native material free of topsoil, organic matter, broken concrete, steel, wood and deleterious substances.

Fabric Strips

"Non-Woven" geotextile filter fabric with a minimum strength equal to or greater than Terrafix 270R, Amoco 4546, Mirafi 140NC or approved equivalent.

10.4 Culvert Installation

Suitable dykes shall be constructed in the drain so that the installation of the pipe can be accomplished in the dry. The drain bottom shall be cleaned, prepared, shaped and compacted to suit the new culvert configuration, as shown on the drawings. Granular materials shall be compacted to 100% of their maximum dry density; imported clean native materials shall be supplied, placed and compacted to 95% of their maximum dry density.

10.5 Sloping Stone End Walls

End walls shall be constructed of quarry stone rip-rap, as specified herein. Each end wall shall extend from the invert of the new culvert to the top of the proposed lane. The end walls shall be sloped 1 vertical to 1.5 horizontal with a filter fabric underlay surrounding the pipe and spanning across the entire width of the drain and wrapping around the drain banks to align with the ends of the new pipe culvert.

The minimum thickness requirement of the erosion stone layer is 300 mm with no portion of the filter fabric to be exposed to sunlight.

10.6 Granular 'A' Driveway

The Contractor shall construct the driveway with a maximum 3% longitudinal grade approach over the new culvert providing a minimum 300 mm cover. This work includes the installation of a minimum 200 mm thickness of compacted Granular 'A' (crushed limestone) surface. The minimum top width of the driveway shall be as shown on the drawings.

10.7 Native Materials

Native materials suitable for use as backfill, as defined under Section 9.2, shall be salvaged from the existing bridge site, as required to complete the work as shown on the drawings, (Native Backfill Zone only). Where there is an insufficient amount of native fill materials for backfilling the culvert, the Contractor may elect to import additional dry native materials or alternatively use Granular 'B' at his/her own expense.

10.8 Lateral Tile Drains

Should the Contractor encounter any lateral tiles within the proposed culvert limits not shown on attached drawings, the Contractor shall re-route the outlet

tile drain(s) in consultation with the Drainage Superintendent, as required, to accommodate the new culvert. Tile drain outlets through the wall of the new culvert pipe will not be permitted. All costs associated with re-routing lateral tile drains (if any) shall be at the Contractor's expense.

Care must be taken in handling plastic drain pipe in cold weather to avoid causing damage.

Plastic drain pipe shall be held in position on planned grade immediately after installation by careful placement of backfill material.

GENERAL SPECIFICATIONS

1.0 AGREEMENT AND GENERAL CONDITIONS

The part of the Specifications headed "Special Provisions" which is attached hereto forms part of this Specification and is to be read with it. Where there is any difference between the requirements of this General Specification and those of the Special Provisions, the Special Provisions shall govern.

Where the word "Drainage Superintendent" is used in this specification, it shall mean the person or persons appointed by the Council of the Municipality having jurisdiction to superintend the work.

Tenders will be received and contracts awarded only in the form of a lump sum contract for the completion of the whole work or of specified sections thereof. The Tenderer agrees to enter into a formal contract with the Municipality upon acceptance of the tender. The General Conditions of the contract and Form of Agreement shall be those of the Stipulated Price Contract CCDC2-Engineers, 1994 or the most recent revision of this document.

2.0 EXAMINATION OF SITE, PLANS AND SPECIFICATIONS

Each tenderer must visit the site and review the plans and specifications before submitting his/her tender and must satisfy himself/herself as to the extent of the work and local conditions to be met during the construction. Claims made at any time after submission of his/her tender that there was any misunderstanding of the terms and conditions of the contract relating to site conditions, will not be allowed. The Contractor will be at liberty, before bidding to examine any data in the possession of the Municipality or of the Engineer.

The quantities shown or indicated on the drawings or in the report are estimates only and are for the sole purpose of indicating to the tenderers the general magnitude of the work. The tenderer is responsible for checking the quantities for accuracy prior to submitting his/her tender.

3.0 MAINTENANCE PERIOD

The successful Tenderer shall guarantee the work for a period of one (1) year from the date of acceptance thereof from deficiencies that, in the opinion of the Engineer, were caused by faulty workmanship or materials. The successful Tenderer shall, at his/her own expense, make good and repair deficiencies and every part thereof, all to the satisfaction of the Engineer.

Should the successful Tenderer for any cause, fail to do so, then the Municipality may do so and employ such other person or persons as the Engineer may deem proper to make such repairs or do such work, and the whole costs, charges and expense so incurred may be deducted from any amount due to the Tenderer or may be collected otherwise by the Municipality from the Tenderer.

4.0 GENERAL CO-ORDINATION

The Contractor shall be responsible for the coordination between the working forces of other organizations and utility companies in connection with this work. The Contractor shall have no cause of action against the Municipality or the Engineer for delays based on the allegation that the site of the work was not made available to him by the Municipality or the Engineer by reason of the acts, omissions, misfeasance or non-feasance of other organizations or utility companies engaged in other work.

5.0 RESPONSIBILITY FOR DAMAGES TO UTILITIES

The Contractor shall note that overhead and underground utilities such as hydro, gas, telephone and water are not necessarily shown on the drawings. It is the Contractor's responsibility to contact utility companies for information regarding utilities, to exercise the necessary care in construction operations and to take other precautions to safeguard the utilities from damage. All work on or adjacent to any utility, pipeline, railway, etc., is to be carried out in accordance with the requirements of the utility, pipeline, railway, or other, as the case may be, and its specifications for such work are to be followed as if they were part of this specification. The Contractor will be liable for any damage to utilities.

6.0 CONTRACTOR'S LIABILITY

The Contractor, his/her agents and all workmen or persons under his/her control including sub-contractors, shall use due care that no person or property is injured and that no rights are infringed in the prosecution of the work. The Contractor shall be solely responsible for all damages, by whomsoever claimable, in respect to any injury to persons or property of whatever description and in respect of any infringement of any right, privilege or easement whatever, occasioned in the carrying on of the work, or by any neglect on the Contractor's part.

The Contractor, shall indemnify and hold harmless the Municipality and the Engineer, their agents and employees from and against claims, demands, losses, costs, damages, actions, suits, or proceedings arising out of or attributable to the

Contractor's performance of the contract.

7.0 PROPERTY BARS AND SURVEY MONUMENTS

The Contractor shall be responsible for marking and protecting all property bars and survey monuments during construction. All missing, disturbed or damaged property bars and survey monuments shall be replaced at the Contractor's expense, by an Ontario Land Surveyor.

8.0 MAINTENANCE OF FLOW

The Contractor shall, at his/her own cost and expense, permanently provide for and maintain the flow of all drains, ditches and water courses that may be encountered during the progress of the work.

9.0 ONTARIO PROVINCIAL STANDARDS

Ontario Provincial Standard Specifications (OPSS) and Ontario Provincial Standard Drawings (OPSD) shall apply and govern at all times unless otherwise amended or extended in these Specifications or on the Drawing. Access to the electronic version of the Ontario Provincial Standards is available online through the MTO website, free of charge to all users. To access the electronic standards on the Web go to <http://www.mto.gov.on.ca/english/transrd/>. Under the title Technical Manuals is a link to the Ontario Provincial Standards. Users require Adobe Acrobat to view all pdf files.

10.0 APPROVALS, PERMITS AND NOTICES

The construction of the works and all operations connected therewith are subject to the approval, inspection, by-laws and regulations of all Municipal, Provincial, Federal and other authorities having jurisdiction in respect to any matters embraced in this Contract. The Contractor shall obtain all approvals and permits and notify the affected authorities when carrying out work in the vicinity of any public utility, power, underground cables, railways, etc.

11.0 SUBLETTING

The Contractor shall keep the work under his/her personal control, and shall not assign, transfer, or sublet any portion without first obtaining the written consent of the Municipality.

12.0 TIME OF COMPLETION

The Contractor shall complete all work on or before the date fixed at the time of tendering. The Contractor will be held liable for any damages or expenses occasioned by his/her failure to complete the work on time and for any expenses of inspection, superintending, re-tendering or re-surveying, due to their neglect or failure to carry out the work in a timely manner.

13.0 TRAFFIC CONTROL

The Contractor will be required to control vehicular and pedestrian traffic along roads at all times and shall, at his/her own expense, provide for placing and maintaining such barricades, signs, flags, lights and flag persons as may be required to ensure public safety. The Contractor will be solely responsible for controlling traffic and shall appoint a representative to maintain the signs and warning lights at night, on weekends and holidays and at all other times that work is not in progress.

All traffic control during construction shall be strictly in accordance with the Occupational Health and Safety Act and the current version of the Ontario Traffic Manuals. Access to the electronic version of the Ontario Traffic Manual is available online through the MTO website, free of charge to all users. To access the electronic standards on the Web go to <http://www.mto.gov.on.ca/english/transrd/>, click on "Library Catalogue," under the "Title," enter "Ontario Traffic Manual" as the search. Open the applicable "Manual(s)" by choosing the "Access Key," once open look for the "Attachment," click the pdf file. Users require Adobe Acrobat to view all pdf files.

Contractors are reminded of the requirements of the Occupational Health and Safety Act pertaining to Traffic Protection Plans for workers and Traffic Control Plan for Public Safety.

14.0 SITE CLEANUP AND RESTORATION

As part of the work and upon completion, the Contractor shall remove and dispose of, off-site any loose timber, logs, stumps, large stones, rubber tires, cinder blocks or other debris from the drain bottom and from the side slopes. Where the construction works cross a lawn, the Contractor shall take extreme care to avoid damaging the lawn, shrubs and trees encountered.

Upon completion of the work, the Contractor shall completely restore the area by the placement and fine grading of topsoil and seeding or sodding the area as specified by the Engineer or Drainage Superintendent.

15.0 UTILITY RELOCATION WORKS

In accordance with Section 26 of the Drainage Act, if utilities are encountered during the installation of the drainage works that conflict with the placement of the new culvert, the operating utility company shall relocate the utility at their own costs. The Contractor however will be responsible to co-ordinate these required relocations (if any) and their co-ordination work shall be considered incidental to the drainage works.

16.0 FINAL INSPECTION

All work shall be carried out to the satisfaction of the Drainage Superintendent for the Municipality, in compliance with the specifications, drawings and the Drainage Act. Upon completion of the project, the work will be inspected by the Engineer and the Drainage Superintendent. Any deficiencies noted during the final inspection shall be immediately rectified by the Contractor.

Final inspection will be made by the Engineer within 20 days after the Drainage Superintendent has received notice in writing from the Contractor that the work is completed, or as soon thereafter as weather conditions permit.

17.0 FISHERIES CONCERNS

Standard practices to be followed to minimize disruption to fish habitat include embedment of the culvert a minimum 10% below grade, constructing the work 'in the dry' and cutting only trees necessary to do the work (no clear-cutting). No in-water work is to occur during the timing window unless otherwise approved by the appropriate authorities.

Nov 12, 2021 - 12:36pm C:\pw working directory\projects to 2017\330em\40613161\176818-03-DRN-CON.dwg

LEGEND

- MUNICIPAL BOUNDARY
- - - ANTAYA DRAIN DRAINAGE AREA
- ANTAYA DRAIN
- OTHER DRAINS
- BRIDGE REPLACEMENT
- ⊗ BRIDGE REMOVAL
- YCB
- LOCAL BENCHMARK
- ▨ WOODLOT AREA

- NOTES:**
- CONSTRUCT SWALES AT EACH PROPERTY LINE BETWEEN STATIONS 0+868 AND 1+025 c/w SEP ON SWALE OUTLET
 - SWALES TO BE CONSTRUCTED WITH MINIMUM 0.3% GRADE AND 5:1 SIDE SLOPES
 - LEVELLING OF MATERIAL OVER PROPERTY Nos. 1-9 NOT TO EXCEED DEPTH OF 100mm

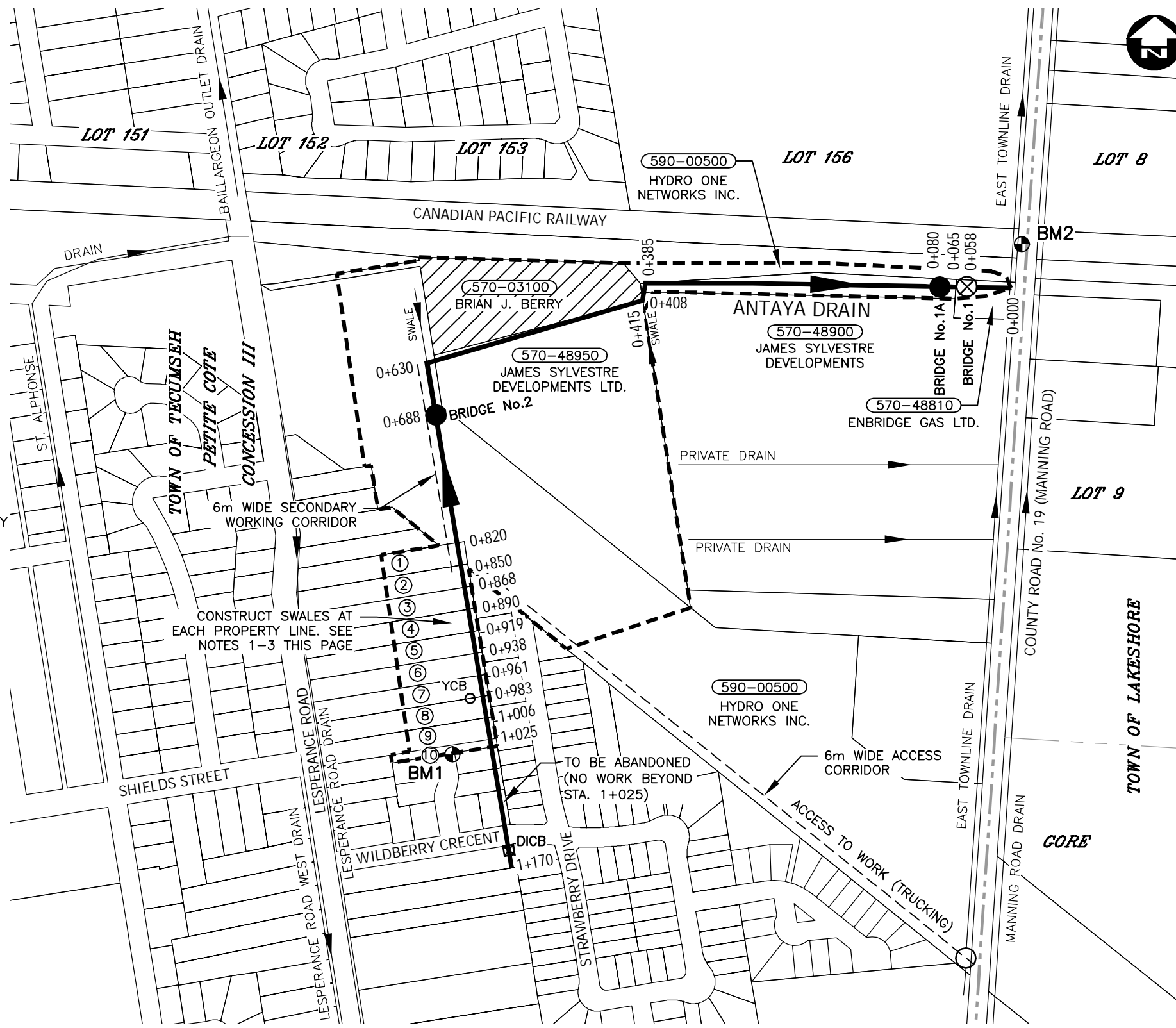

SITE BENCHMARKS

GBM-TECUMSEH BM#4-26338 05. PKNAIL IN TOP OF CONCRETE PUMP STATION ON NORTH SIDE OF SHIELDS AVENUE LOCATED OPPOSITE THE NORTHERLY PROJECTION OF THE EAST WALL OF TECUMSEH VISTA SCHOOL.
ELEVATION=183.509m

BM1-TOP OF OPERATING NUT ON FIRE HYDRANT ON PROPERTY MUNICIPAL No. 2490 BLUEBERRY CRT. (345184.44, 4682922.94)
ELEVATION=183.986m

BM2-TOP OF STANDARD IRONBAR, SOUTH WEST CORNER OF CPR TRACKS AT MANNING ROAD. (345769.27, 4683443.57)
ELEVATION=182.44m

NOTE: CONTRACTOR TO VERIFY BENCHMARKS PRIOR TO CONSTRUCTION.

PARCEL INFORMATION

#	ROLL No.	PROPERTY OWNER
1	570-02600	FARINA G. KEUHFUSS
2	570-02500	MARIE A. GAGNIER
3	570-02400	CAROLE KITCHING
4	570-02300	BLAZE, ANKA & LJUBICA RISTOVSKI
5	570-02200	BRIAN & KAREN RUTHERFORD
6	570-02100	MARY A. LEE
7	570-02000	LEHMBER S. & KULWANT K. PAHAL
8	570-01900	DANIEL R. BEAULIEU
9	570-01800	PAUL A. ADAMS

#	PIN	PROPERTY OWNER
10	75329-0156	JAMES SYLVESTRE DEVELOPMENTS LTD.

NOTE: CONTRACTOR IS RESPONSIBLE TO ARRANGE UTILITY LOCATES PRIOR TO CONSTRUCTION

OVERALL PLAN
SCALE=1:5,000



Conditions of Use

Verify elevations and/or dimensions on drawing prior to use. Report any discrepancies to Dillon Consulting Limited.

Do not scale dimensions from drawing.

Do not modify drawing, re-use it, or use it for purposes other than those intended at the time of its preparation without prior written permission from Dillon Consulting Limited.

No.	ISSUED FOR	DATE	BY
3	FINAL SUBMISSION	12NOV21	MDH
2	PUBLIC INFORMATION CENTRE	10CT21	MDH
1	CLIENT REVIEW	22NOV19	MDH

DESIGN	REVIEWED BY
MDH	EPS
DRAWN	CHECKED BY
OEM	TRO
DATE	November 12, 2021
SCALE	AS SHOWN

DILLON CONSULTING

PROJECT NO. 17-6818

DRAWING SCALES BASED ON A 11" X 17" SHEET

'SCHEDULE G'

Drainage Report for the
ANTAYA DRAIN
Town of Tecumseh
County of Essex

SHEET TITLE	OVERALL PLAN
PAGE NO.	1 of 5

Nov 12, 2021 - 12:36pm C:\pwworking\directory\projects to 2017\33oem\d0613161\176818-03-XSF-DES.dwg

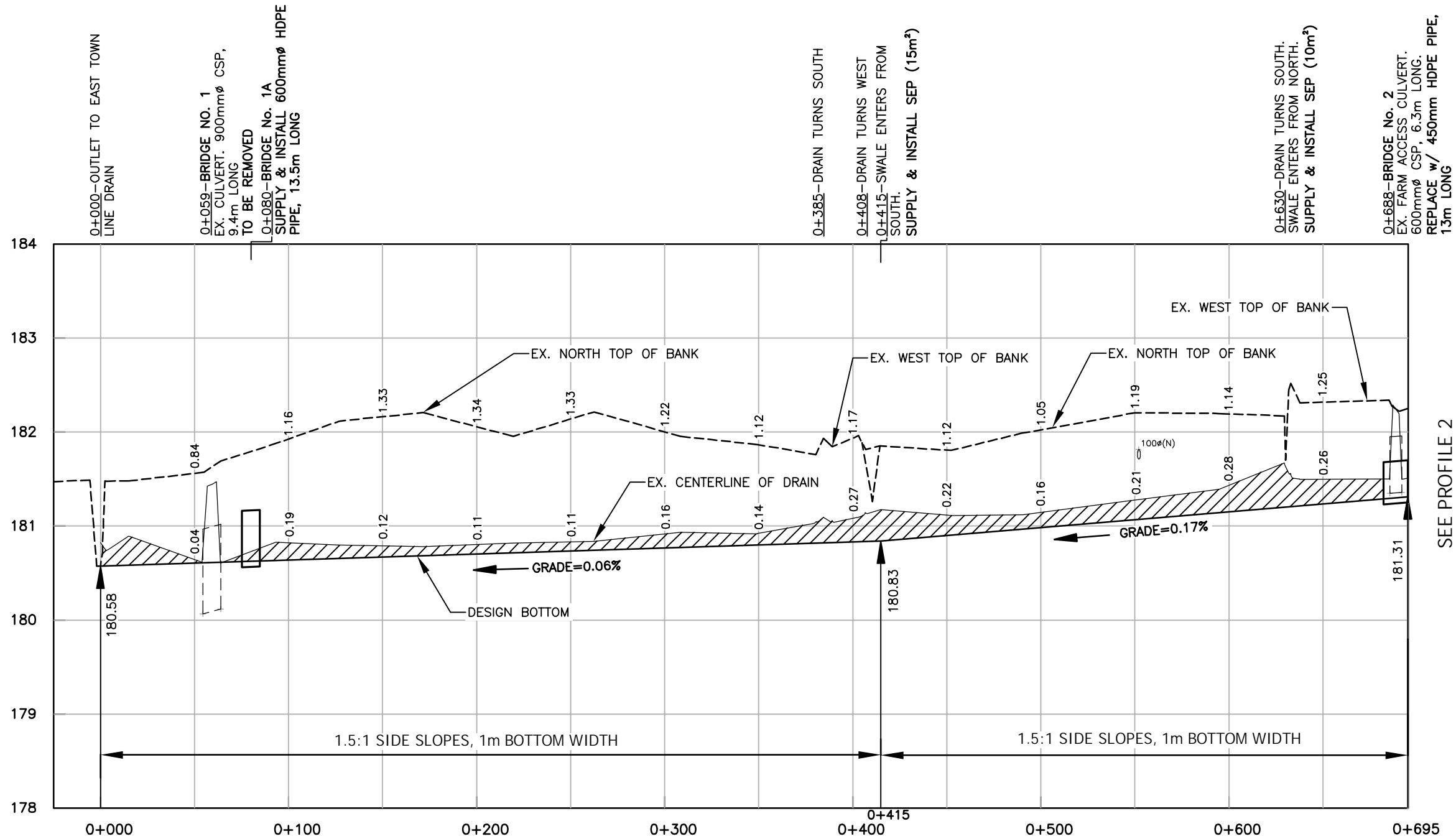

SEE PROFILE 2

PROFILE 1
SCALE - HORZ.=1:2,500
VERT.=1:50



Conditions of Use
Verify elevations and/or dimensions on drawing prior to use. Report any discrepancies to Dillon Consulting Limited.
Do not scale dimensions from drawing.
Do not modify drawing, re-use it, or use it for purposes other than those intended at the time of its preparation without prior written permission from Dillon Consulting Limited.

No.	ISSUED FOR	DATE	BY
3	FINAL SUBMISSION	12NOV21	MDH
2	PUBLIC INFORMATION CENTRE	10CT21	MDH
1	CLIENT REVIEW	22NOV19	MDH

DESIGN	MDH	REVIEWED BY	EPS
DRAWN	OEM	CHECKED BY	TRO
DATE	November 12, 2021		
SCALE	AS SHOWN		

PROJECT NO. 17-6818
DRAWING SCALES BASED ON A 11" X 17" SHEET

'SCHEDULE G'
Drainage Report for the
ANTAYA DRAIN
Town of Tecumseh
County of Essex

SHEET TITLE: **PROFILE 1**
PAGE NO.: 2 of 5

Nov 12, 2021 - 12:36pm C:\pwworking\directory\projects to 2017\33oem\d0613161\176818-03-XSF-DES.dwg

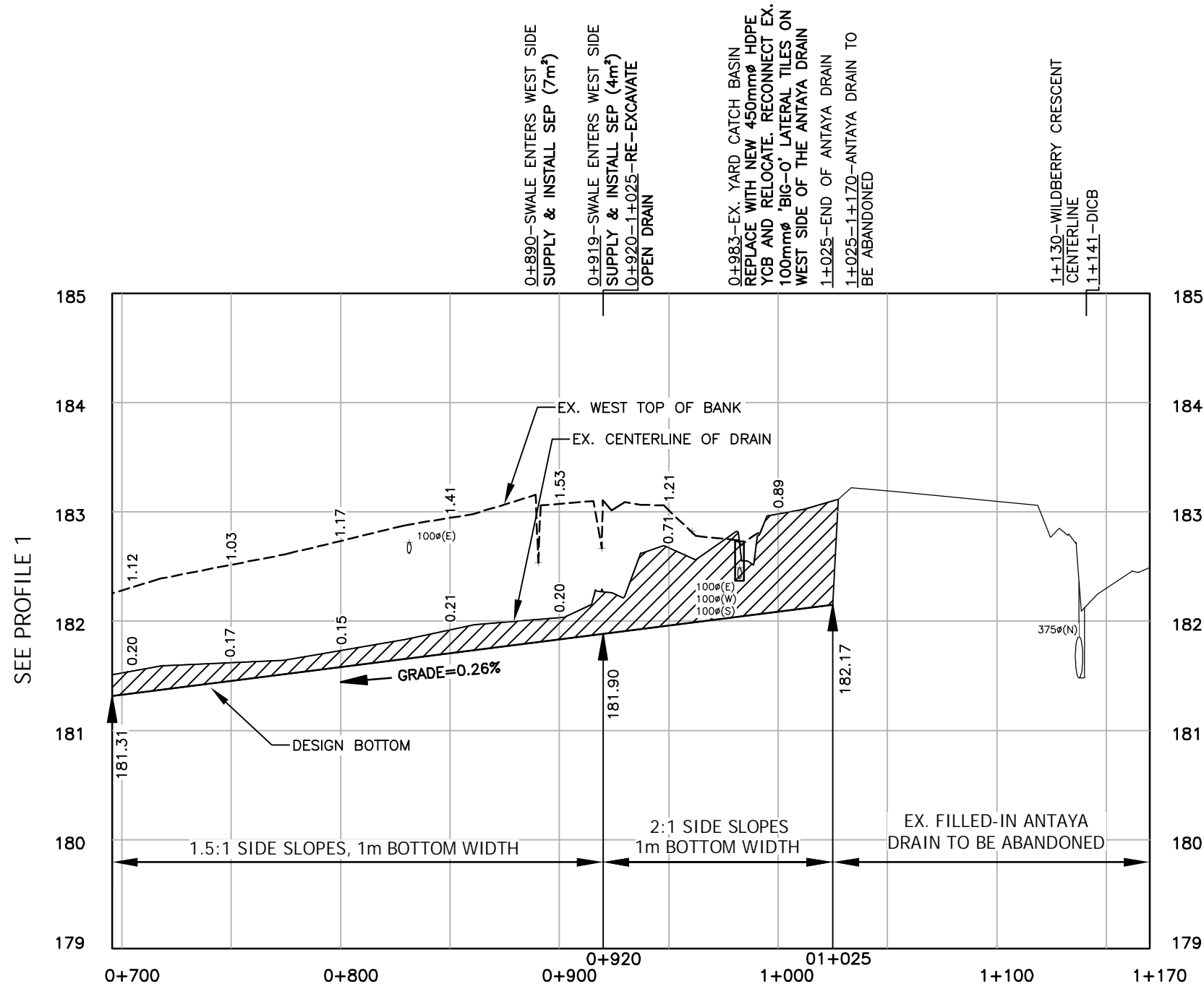

0+890-SWALE ENTERS WEST SIDE SUPPLY & INSTALL SEP (7m²)

0+919-SWALE ENTERS WEST SIDE SUPPLY & INSTALL SEP (4m²)

0+920-1+025-RE-EXCAVATE OPEN DRAIN

0+983-EX. YARD CATCH BASIN REPLACE WITH NEW 450mm ϕ HDPE YCB AND RELOCATE. RECONNECT EX. 100mm ϕ 'BIG-O' LATERAL TILES ON WEST SIDE OF THE ANTAYA DRAIN

1+025-END OF ANTAYA DRAIN

1+025-1+170-ANTAYA DRAIN TO BE ABANDONED

1+130-WILDBERRY CRESCENT CENTERLINE

1+141-DICB

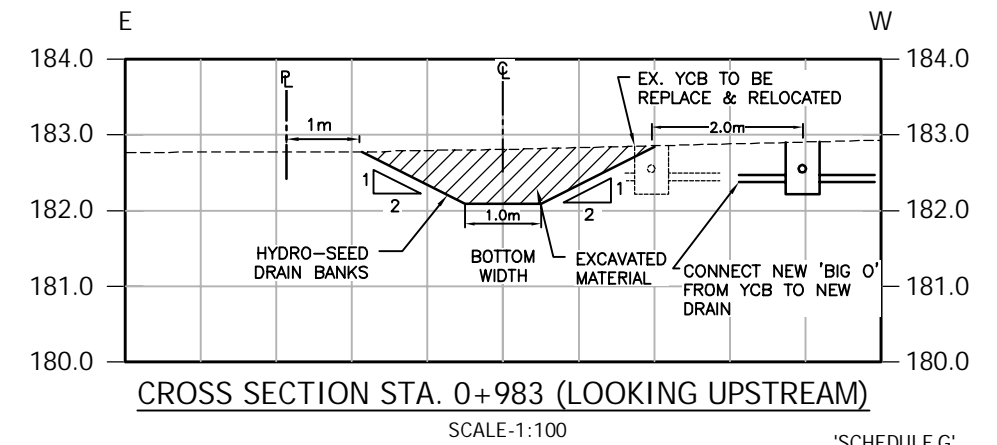
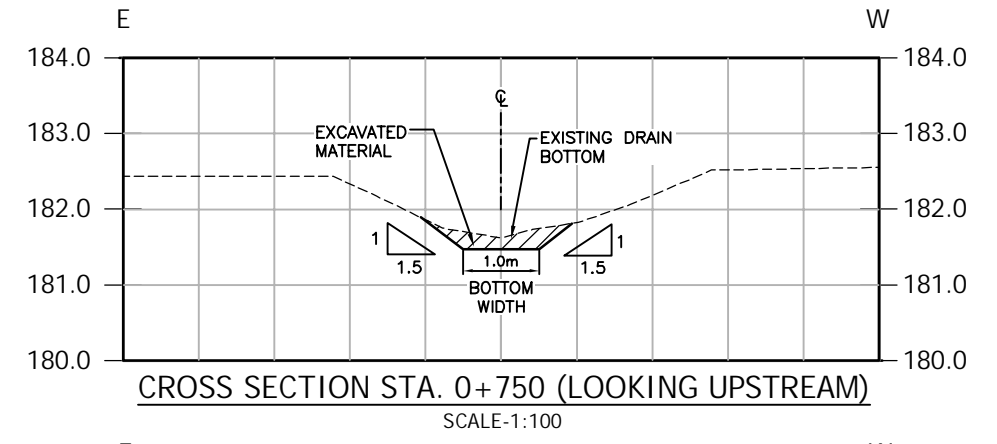
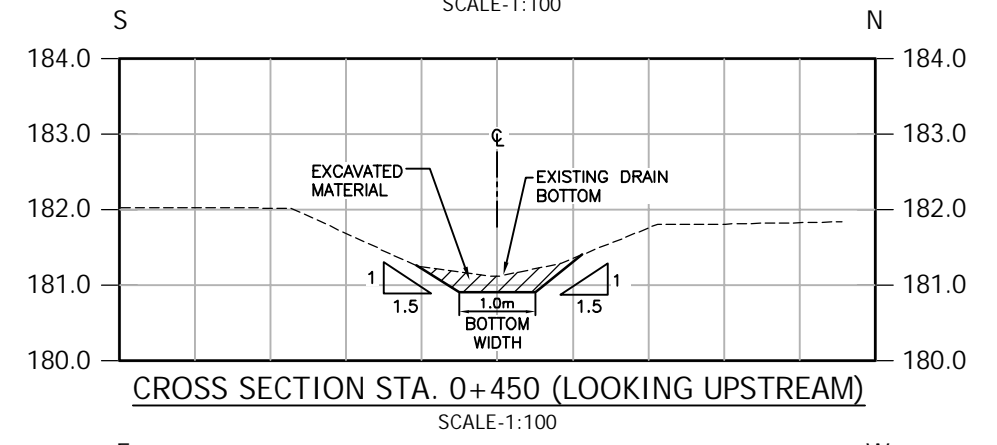
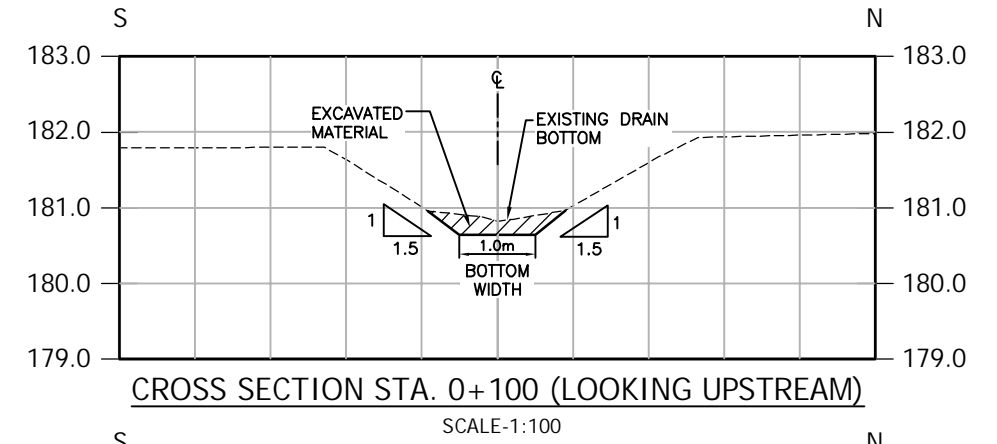

Conditions of Use

Verify elevations and/or dimensions on drawing prior to use. Report any discrepancies to Dillon Consulting Limited.

Do not scale dimensions from drawing.

Do not modify drawing, re-use it, or use it for purposes other than those intended at the time of its preparation without prior written permission from Dillon Consulting Limited.

No.	ISSUED FOR	DATE	BY
3	FINAL SUBMISSION	12NOV21	MDH
2	PUBLIC INFORMATION CENTRE	10CT21	MDH
1	CLIENT REVIEW	22NOV19	MDH

DESIGN	MDH	REVIEWED BY	EPS
DRAWN	OEM	CHECKED BY	TRO
DATE	November 12, 2021		
SCALE	AS SHOWN		

DILLON CONSULTING

PROJECT NO. 17-6818

DRAWING SCALES BASED ON A 11" X 17" SHEET

'SCHEDULE G'	
Drainage Report for the ANTAYA DRAIN Town of Tecumseh County of Essex	
SHEET TITLE	PROFILE 2 & CROSS-SECTIONS
PAGE NO.	3 of 5

Nov 12, 2021 - 12:36pm C:\pwworking\directory\projects to 2017\330em\d0613161\176818-03-XSF-DES.dwg

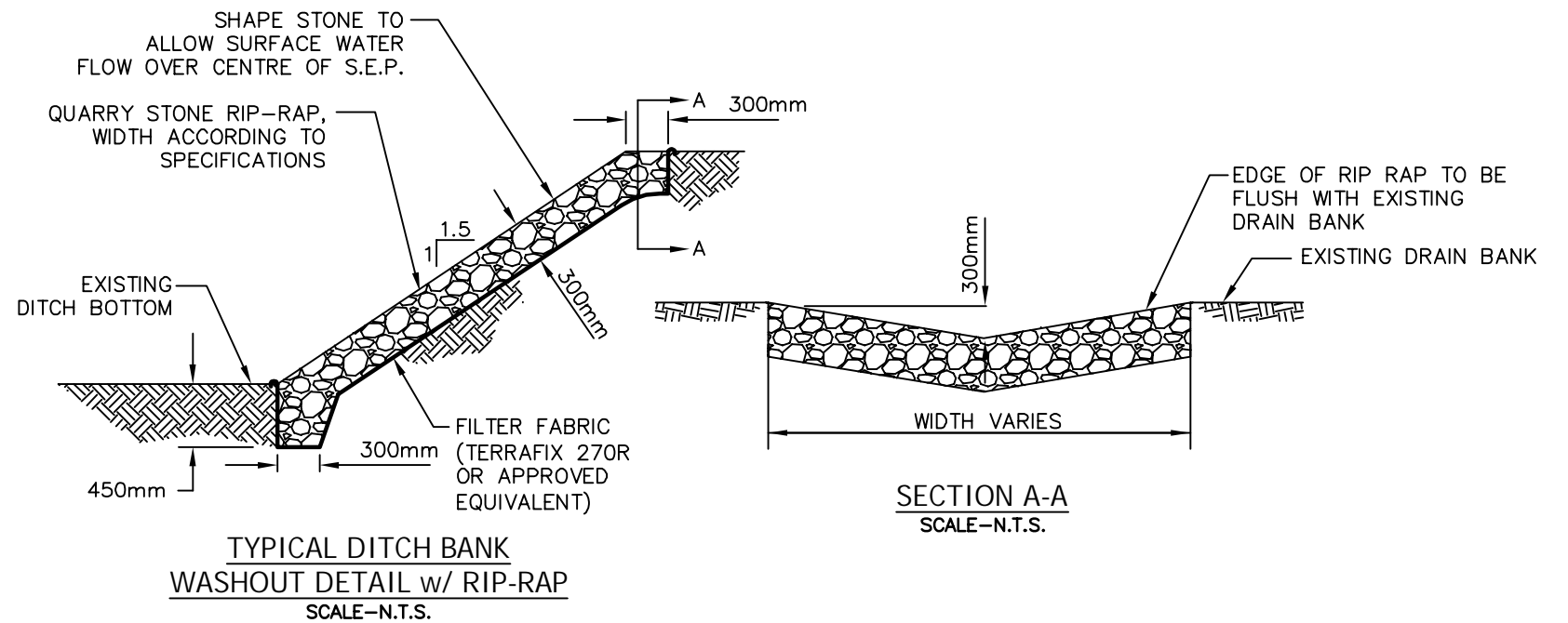
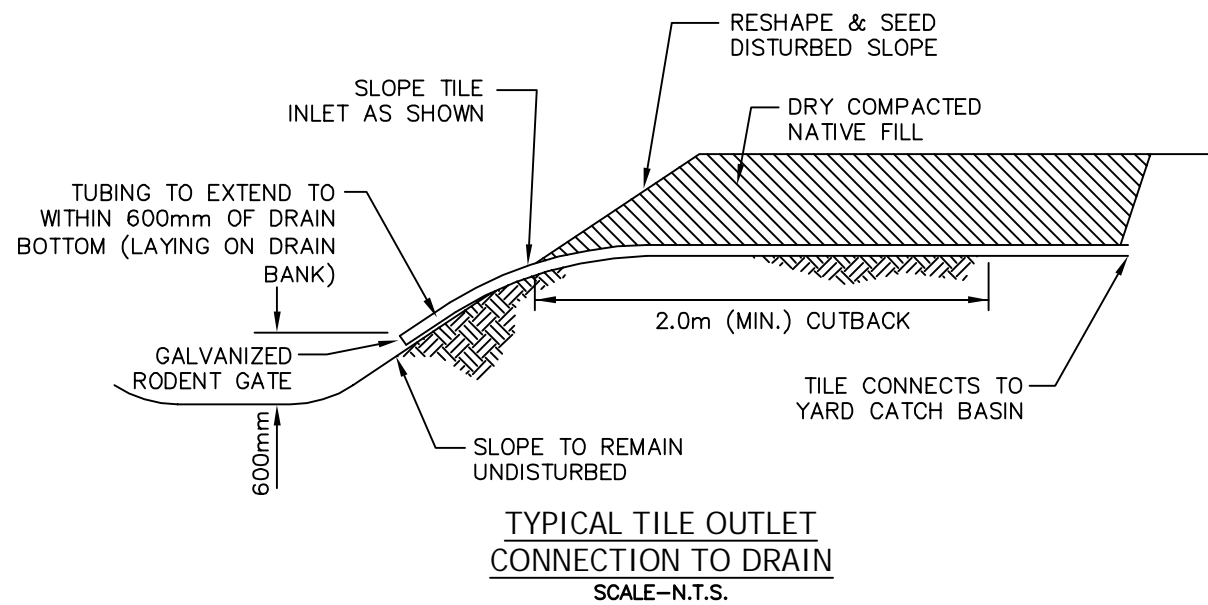
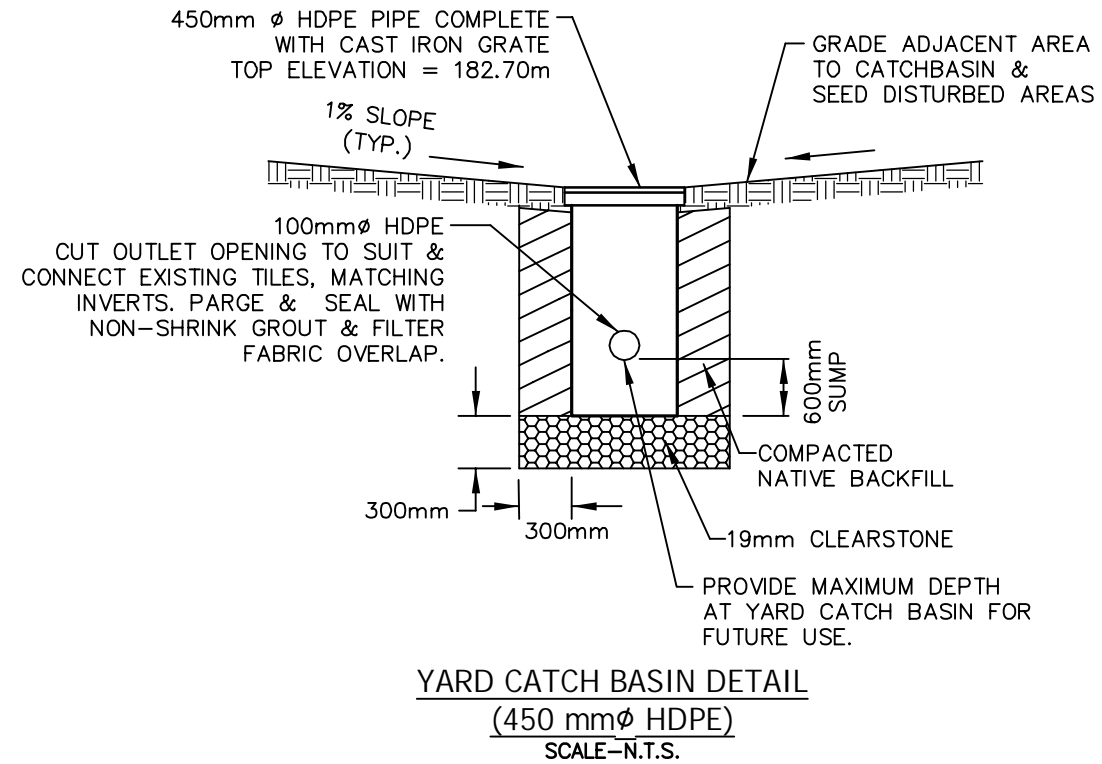
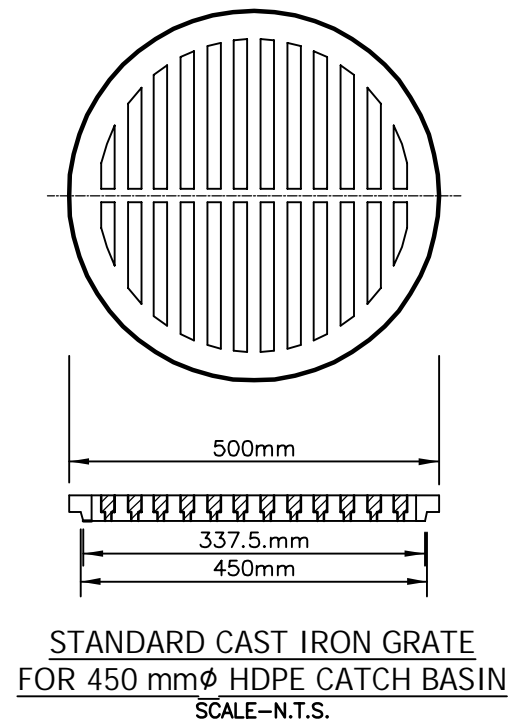

Conditions of Use
 Verify elevations and/or dimensions on drawing prior to use. Report any discrepancies to Dillon Consulting Limited.
 Do not scale dimensions from drawing.
 Do not modify drawing, re-use it, or use it for purposes other than those intended at the time of its preparation without prior written permission from Dillon Consulting Limited.

No.	ISSUED FOR	DATE	BY
3	FINAL SUBMISSION	12NOV21	MDH
2	PUBLIC INFORMATION CENTRE	10CT21	MDH
1	CLIENT REVIEW	22NOV19	MDH

DESIGN	REVIEWED BY
MDH	EPS
DRAWN	CHECKED BY
OEM	TRO
DATE	November 12, 2021
SCALE	AS SHOWN

PROJECT NO. 17-6818
 DRAWING SCALES BASED ON A 11" X 17" SHEET

'SCHEDULE G'	
Drainage Report for the ANTAYA DRAIN Town of Tecumseh County of Essex	
SHEET TITLE	DETAILS
PAGE NO.	4 of 5

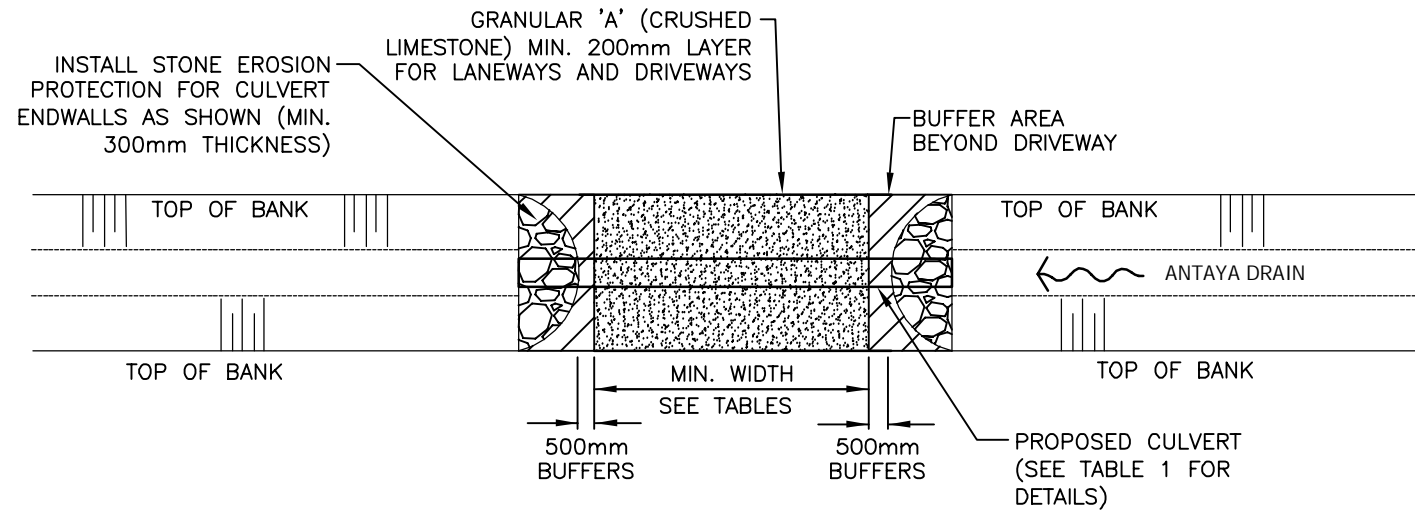

BRIDGE PLAN
N.T.S.

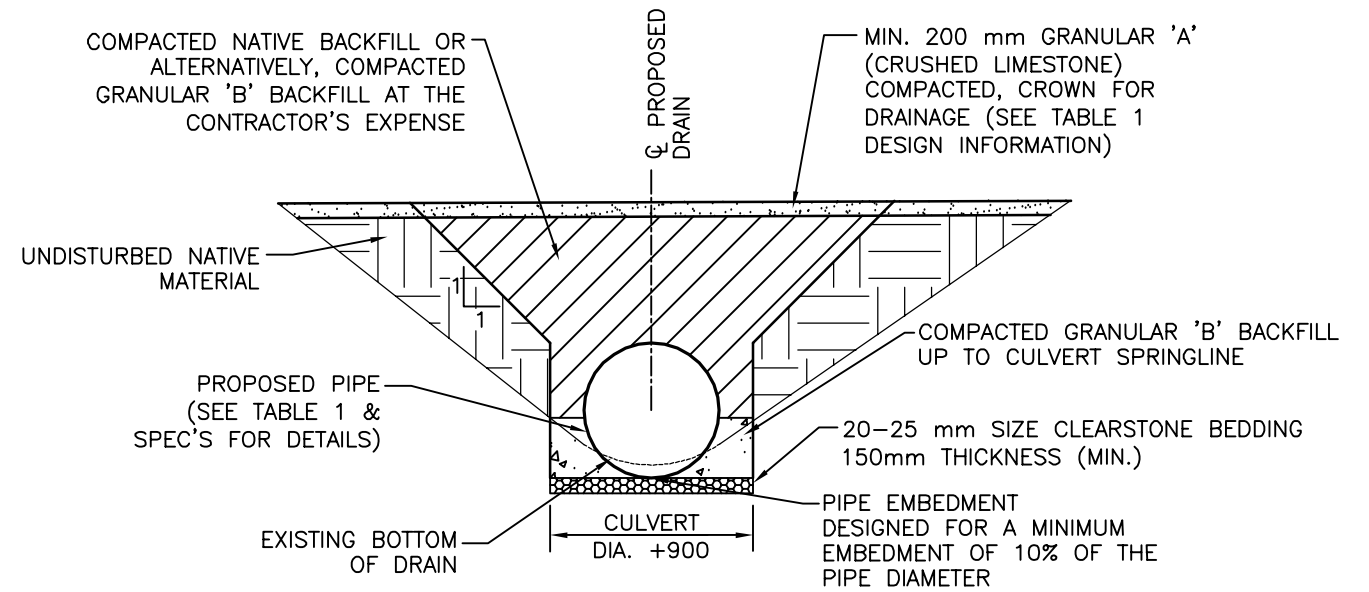

CROSS SECTION
N.T.S.

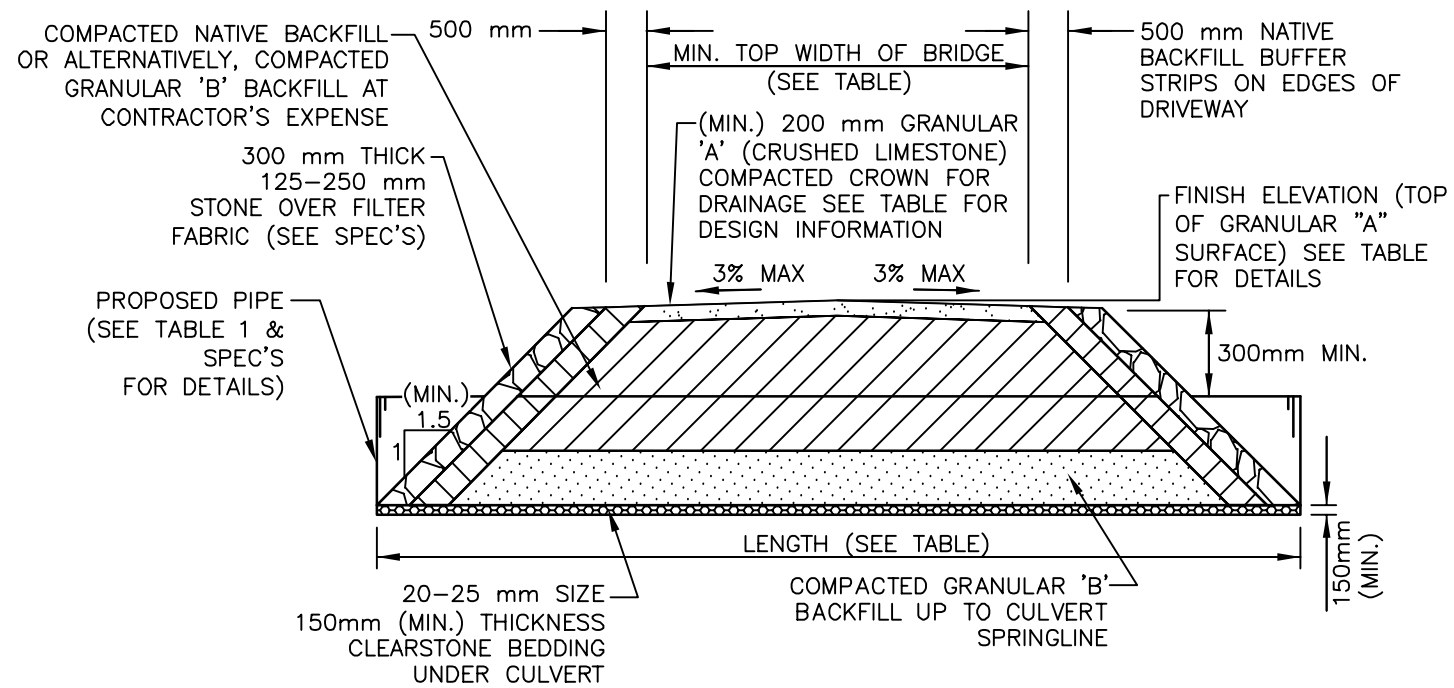

LONGITUDINAL SECTION
N.T.S.

DESCRIPTION	BRIDGE No.1A	BRIDGE No.2
PIPE INVERT ELEV. U/S SIDE(m)	180.58	181.25
PIPE INVERT ELEV. D/S SIDE(m)	180.57	181.23
TOP OF ϕ DRIVEWAY SURFACE ELEV. (m)	181.87	182.50
DRAIN BOTTOM (m) (DESIGN) (AT CENTRELINE OF CULVERT)	180.64	181.31
MIN. TOP WIDTH OF DRIVEWAY (m)	7.3	7.3
MIN. CULVERT GRADE (%)	0.10	0.10
CULVERT TYPE	320 kPa	320 kPa
CULVERT MATERIAL	H.D.P.E.	H.D.P.E.
CULVERT LENGTH (m)	13.5	13.0
PIPE SIZE (mm)	600	450
CULVERT ENDWALL TYPE	SLOPING STONE	SLOPING STONE



Conditions of Use

Verify elevations and/or dimensions on drawing prior to use. Report any discrepancies to Dillon Consulting Limited.
Do not scale dimensions from drawing.
Do not modify drawing, re-use it, or use it for purposes other than those intended at the time of its preparation without prior written permission from Dillon Consulting Limited.

No.	ISSUED FOR	DATE	BY
3	FINAL SUBMISSION	12NOV21	MDH
2	PUBLIC INFORMATION CENTRE	10CT21	MDH
1	CLIENT REVIEW	22NOV19	MDH

DESIGN	REVIEWED BY
MDH	EPS
DRAWN	CHECKED BY
OEM	TRO
DATE	November 12, 2021
SCALE	AS SHOWN

PROJECT NO. 17-6818
DRAWING SCALES BASED ON A 11" X 17" SHEET

'SCHEDULE G'	
Drainage Report for the ANTAYA DRAIN Town of Tecumseh County of Essex	
SHEET TITLE	BRIDGE DETAILS
PAGE NO.	5 of 5